

**Agilent Technologies 8960 Series 10 E5515B,C Wireless Communications Test Set  
Agilent Technologies E1961A AMPS/136 Mobile Test Application**

## **GPIB Command Syntax**

Test Application Revision A.04

© Copyright Agilent Technologies 2001  
All Rights Reserved

**<http://www.agilent.com/find/8960support/>**



**Agilent Technologies**

---

## **Notice**

Information contained in this document is subject to change without notice.

All Rights Reserved. Reproduction, adaptation, or translation without prior written permission is prohibited, except as allowed under the copyright laws.

This material may be reproduced by or for the U.S. Government pursuant to the Copyright License under the clause at DFARS 52.227-7013 (APR 1988).

Agilent Technologies, Inc.  
Learning Products Department  
24001 E. Mission  
Liberty Lake, WA 99019-9599  
U.S.A.

---

## Contents

Diagram Conventions .....	7
Description .....	8
ABORT .....	12
AFGenerator .....	13
CALibration .....	14
CALL:ACC .....	15
CALL:AVCTest .....	16
CALL:CCHannel .....	17
CALL:CONNected .....	18
CALL:CONTRol:DOWNlink:FREQuency:AUTO .....	19
CALL:DCCH .....	20
CALL:DTC:BURSt .....	21
CALL:END .....	22
CALL:DTC:IBERror .....	23
CALL:FM .....	24
CALL:HANDoff .....	25
CALL:MCCode .....	26
CALL:MS .....	27
CALL:OPERating .....	32
CALL:ORIGinate .....	33
CALL:PAGing:PNUMBER .....	34
CALL:PAGing:REPeat .....	35

---

## Contents

CALL:POWer	36
CALL:REGister	38
CALL:RFGenerator	39
CALL:SETup	40
CALL:SID	43
CALL:SOCode	44
CALL:STATus	45
CALL:TCHannel	46
DISPlay	47
FETCh:ACPower	48
FETCh:AFANalyzer	50
FETCh:ATXPower	54
FETCh:DPOWer	55
FETCh:DTXPower	57
FETCh:FM	58
FETCh:FSTability	61
FETCh:IQTuning	63
FETCh:LBERror	64
FETCh:MACCuracy	65
INITiate	71
READ	73
RFANalyzer	75

---

## Contents

SETup[:ALL]:CONTinuous	78
SETup:ACPower	79
SETup:AFANalyzer	81
SETup:ATXPower	85
SETup:DPOwer	87
SETup:DTXPower	89
SETup:FM	91
SETup:FSTability	95
SETup:IQTuning	97
SETup:LBError	101
SETup:MACCuracy	102
STATus:OPERation	104
STATus:PRESet	112
STATus:QUEStionable	113
Status Byte Register	126
Standard Event Status Register	129
SYSTem:APPLication	134
SYSTem:BEEPer	136
SYSTem:COMMunicate	137
SYSTem:CONFigure:INFormation:HARDware:VERBose?	138
SYSTem:CORRection	139
SYSTem:CURRent:TA	141

---

**Contents**

SYSTem:ERRor? .....	142
SYSTem:MEASurement:RESet .....	143
SYSTem:PRESet .....	144
SYSTem:ROSCillator .....	145
SYSTem:SYNChronized .....	146
IEEE 488.2 Common Commands .....	147
Description .....	147

## **Diagram Conventions**

## Description

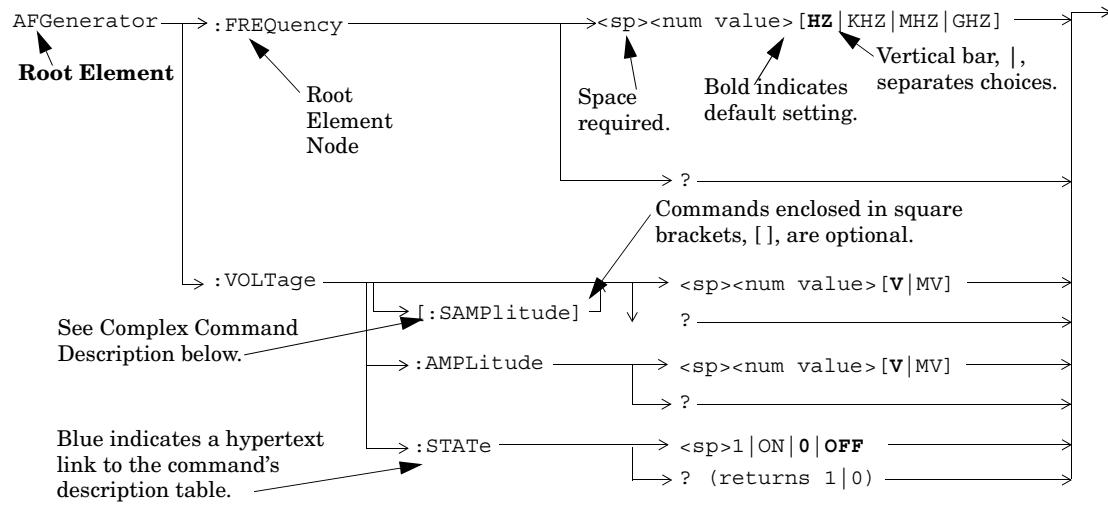



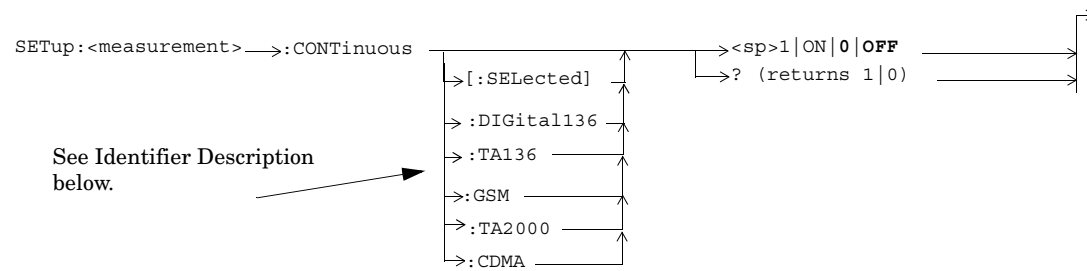

### **Diagram Description**

Statement elements are connected by lines. Each line can be followed in only one direction, as indicated by the arrow at the end of the line. Any combination of statement elements that can be generated by starting at the **Root Element** and following the line the **direction of the arrow** is syntactically correct. The drawings show the proper use of spaces. Where spaces are required they are indicated by **<sp>**, otherwise no spaces are allowed between statement elements.

### **Complex Command Description**

A complex command sets the state of the parameter to ON, and is used to set a value for that parameter. These parameters; amplitude, frequency, gain, number, time, and value can be used as a complex command. Refer to the specific command for the parameter that applies.

### **Identifier Description**

Some test applications are able to test more than one radio format. There may be commands/queries that are shared by more than one radio format in the some of these test applications. Identifiers are used to specify the radio format for the command/query. The command/query is sent to the active radio format if you don't use an identifier. An identifier must be used when sending commands to the inactive radio format.

### **Developing Code**

It is recommended that you set the Test Set's operating environment to debug. To set the Test Set debug mode to "ON" use the following syntax:

```
SYSTem:COMMunicate:GPIB:DEBug ON
```

### **Units-of-Measure**

Amplitude (linear)	V
Frequency	Hz
Power (logarithmic)	dBm
Time	s

## ABORT

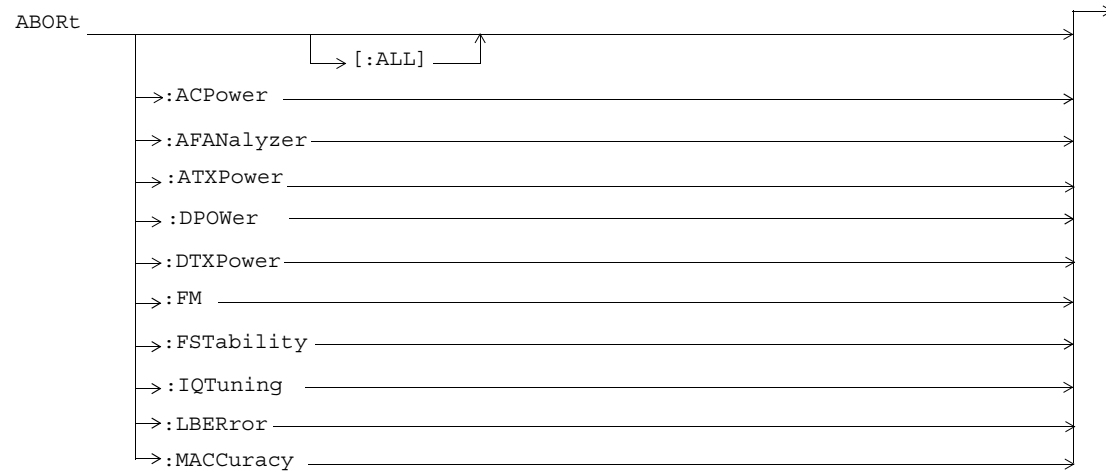

## AFGenerator

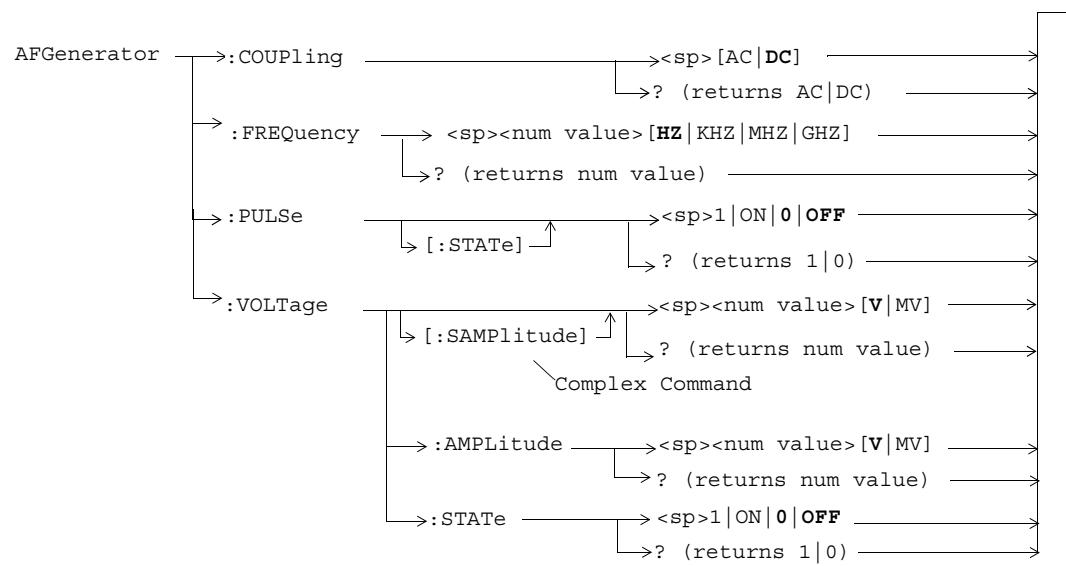

## CALibration

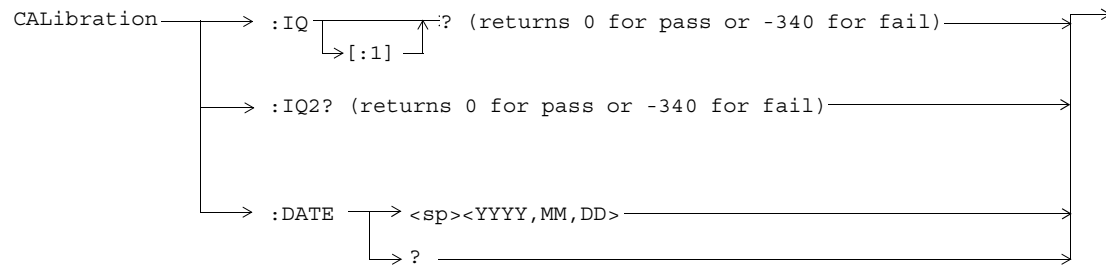

## CALL:ACC

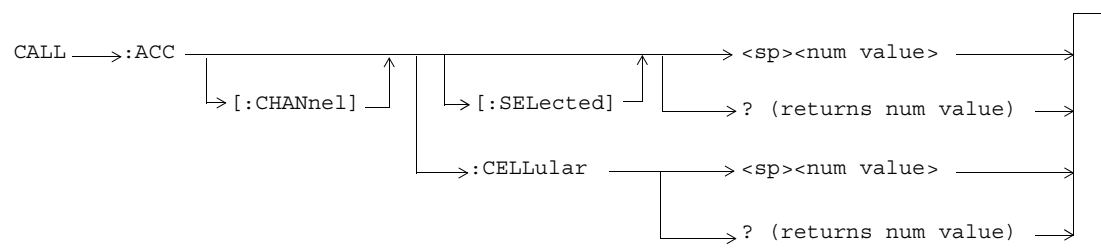

### CALL:AVCTest

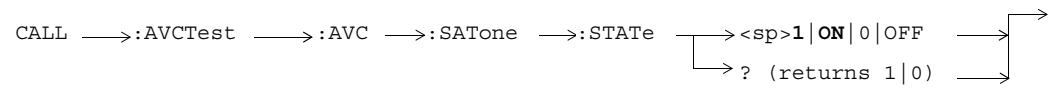



### CALL:CCHannel

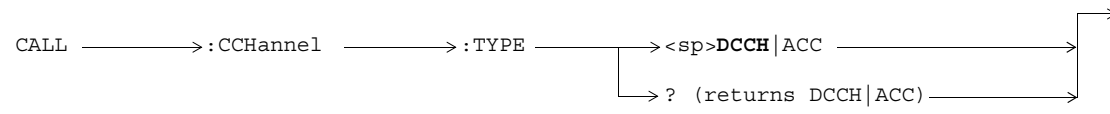

## CALL:CONNEcted

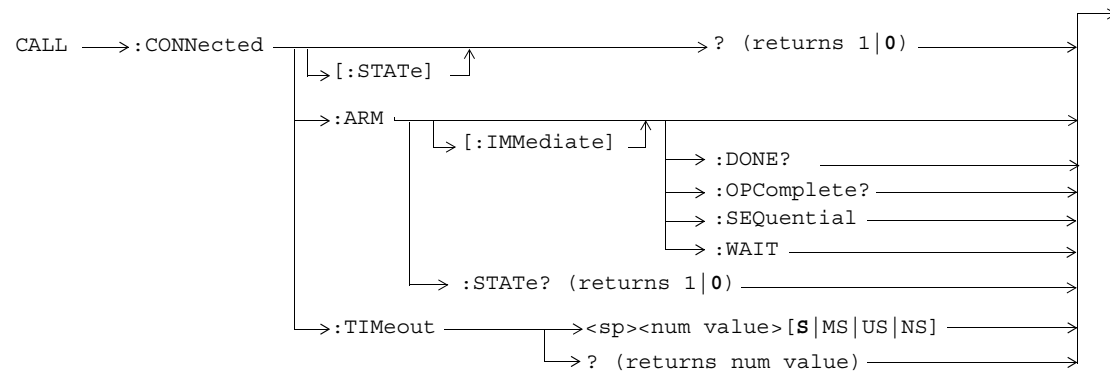

### **CALL:CONTROL:DOWNlink:FREQuency:AUTO**

CALL →:CONTROL →:DOWNlink → :FREQuency → :AUTO →<sp>1|ON|0|OFF →  
└─? (returns 1|0) →

## CALL:DCCH

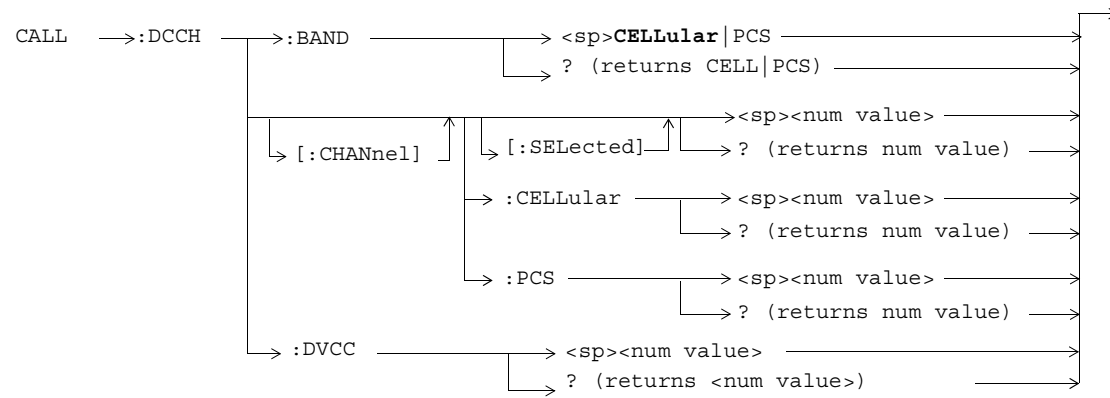

### CALL:DTC:BURSt

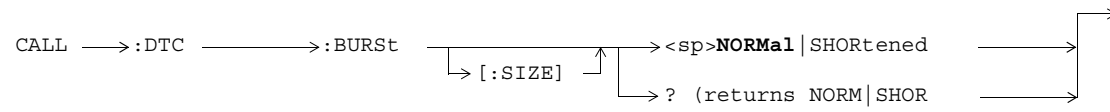

**CALL:END**

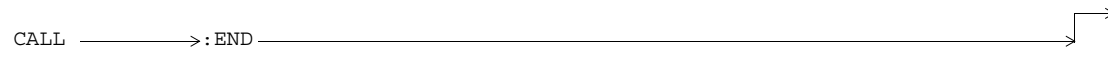

### CALL:DTC:IBERror

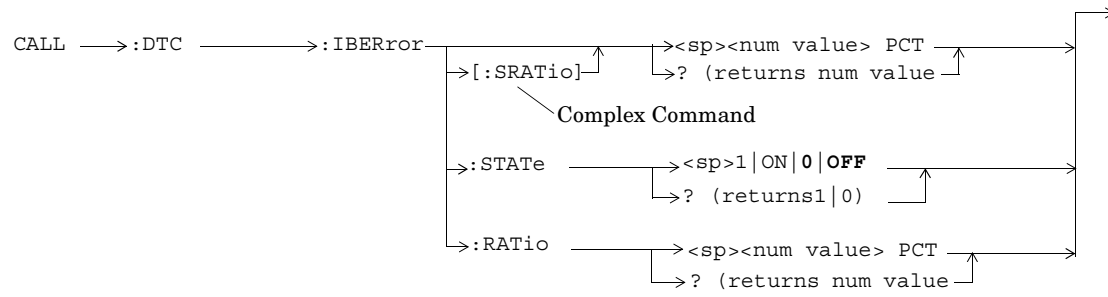

## CALL:FM

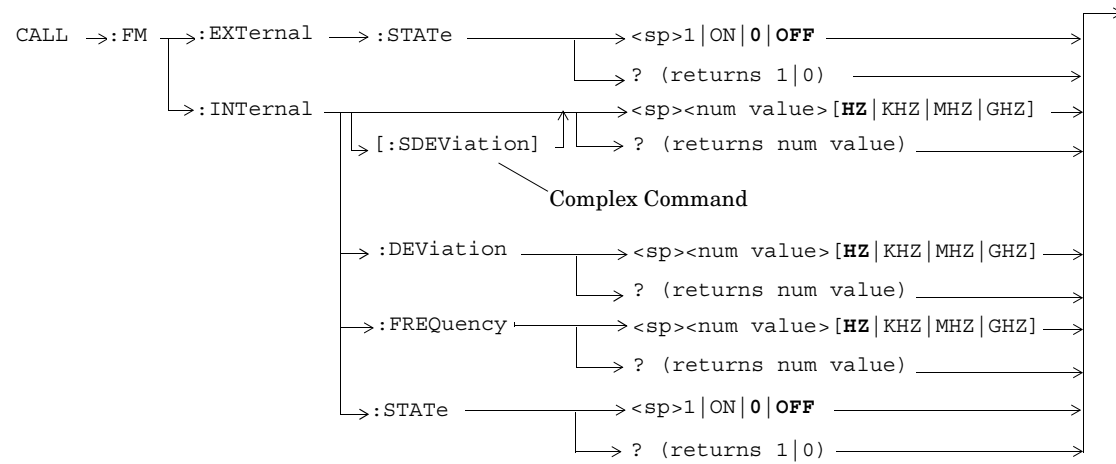



## CALL:HANDoff

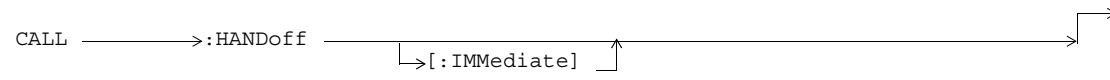

### CALL:MCCode

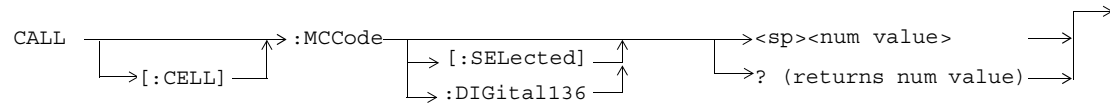

## CALL:MS

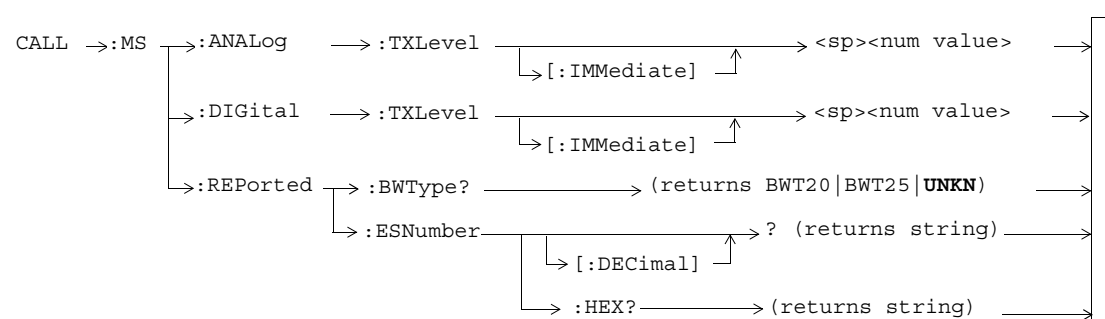

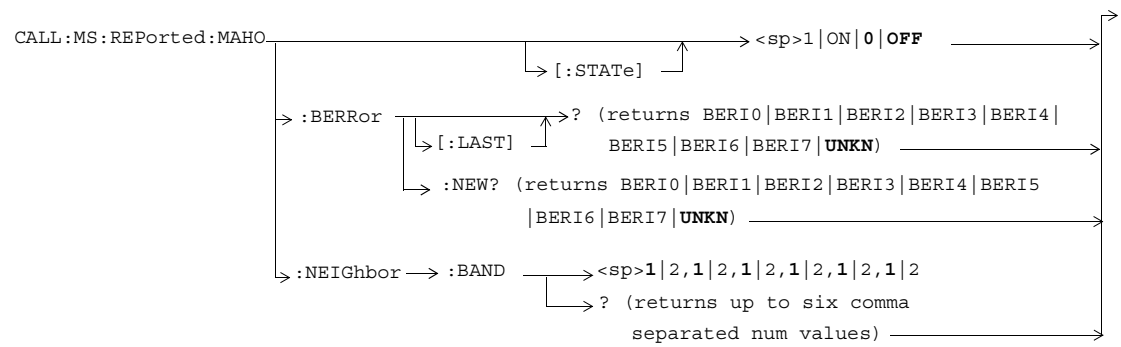

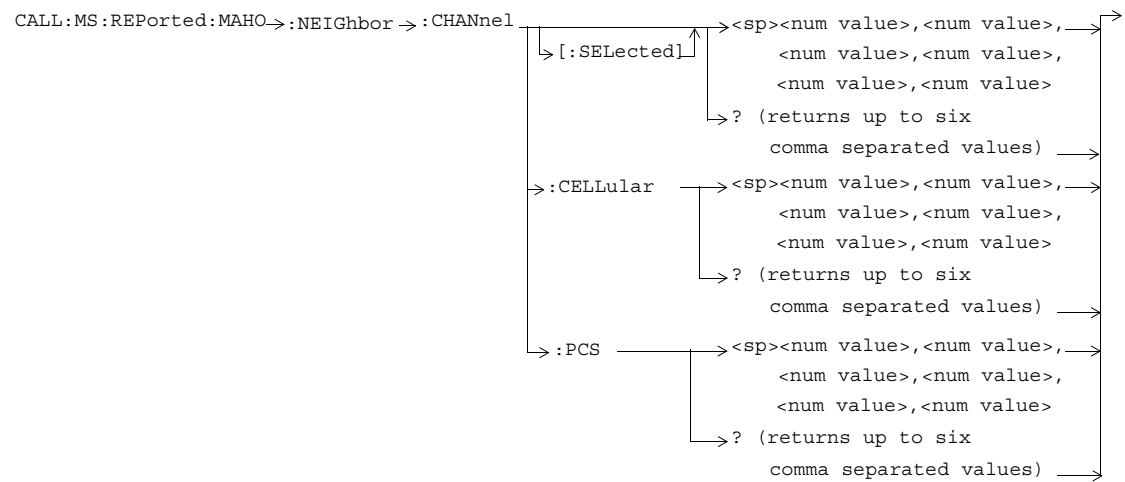

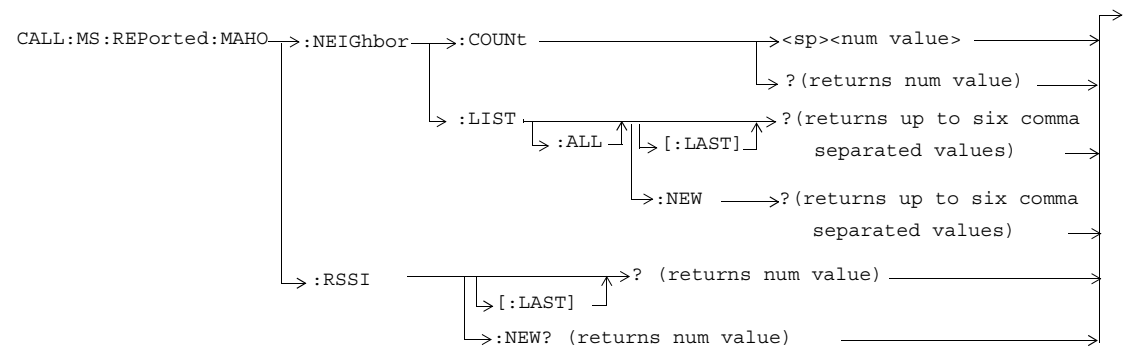

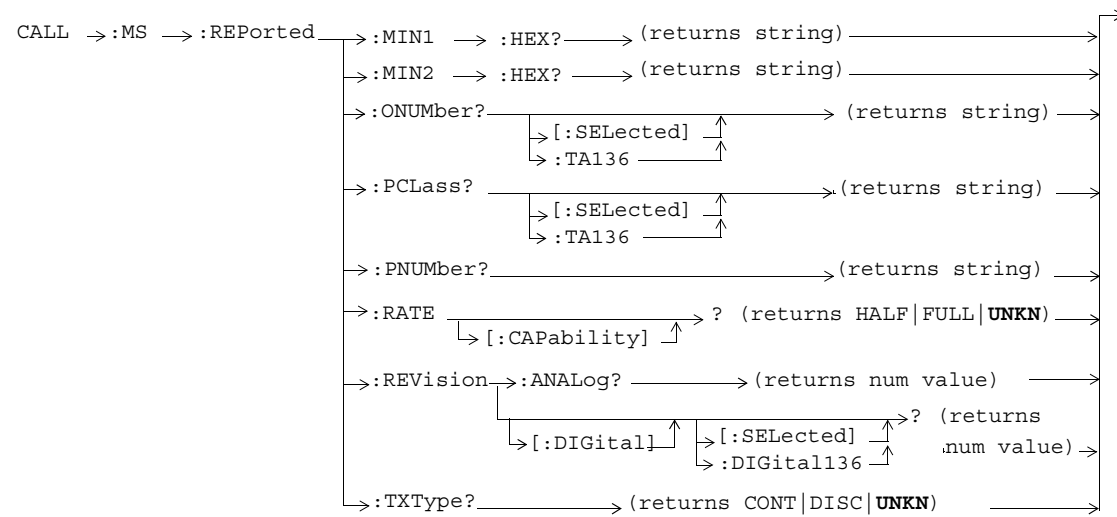

(Not supported in the first release of this mobile test application.)

### CALL:OPERating

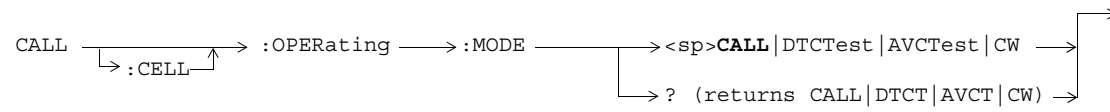



### CALL:ORIGinate

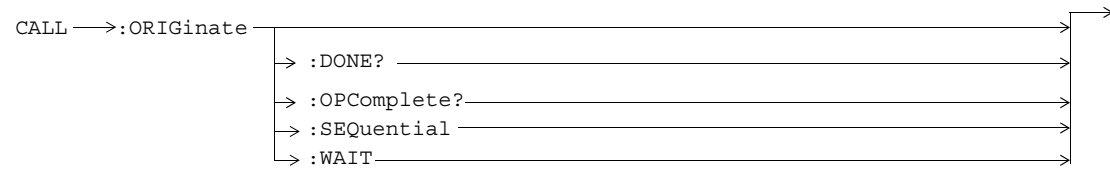

### CALL:PAGing:PNUMber

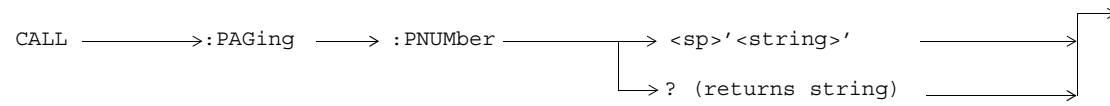

### CALL:PAGing:REPeat

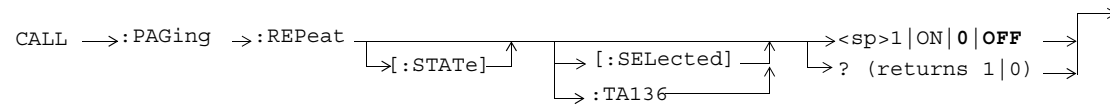

## CALL:POWer

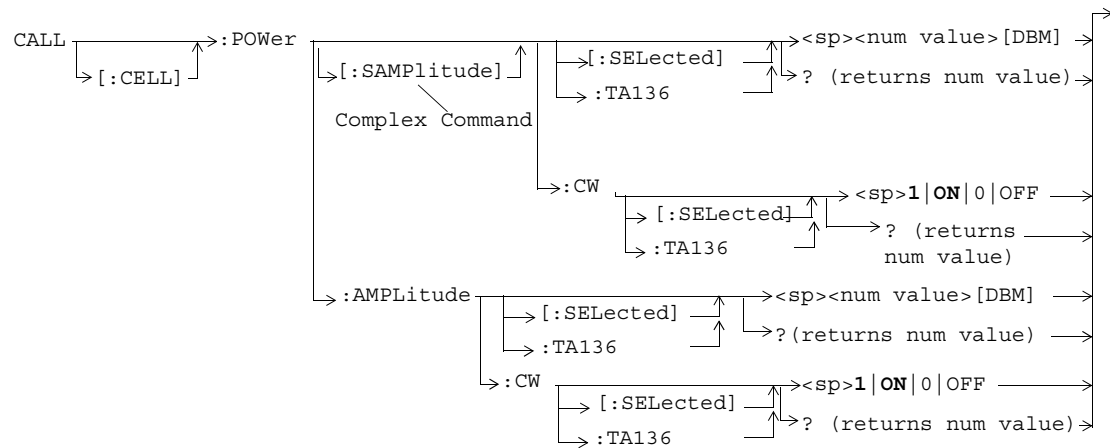

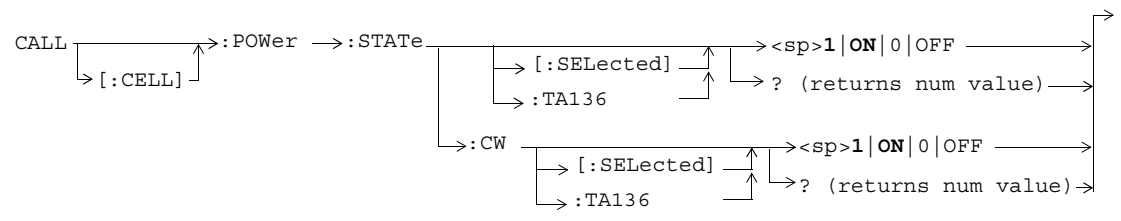

### CALL:REGister

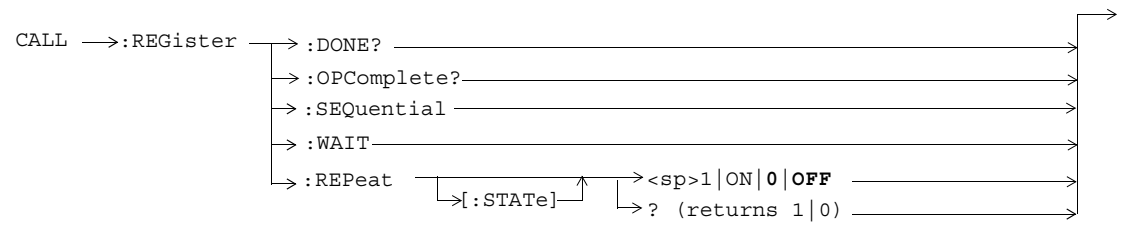

### CALL:RFGenerator

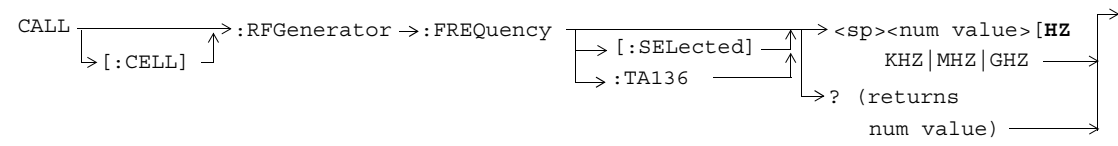

## CALL:SETup

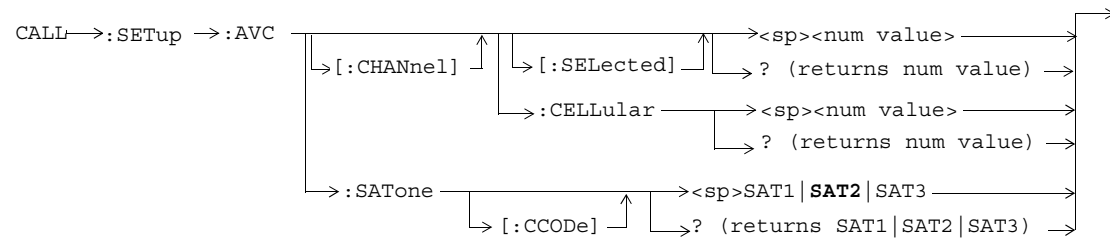



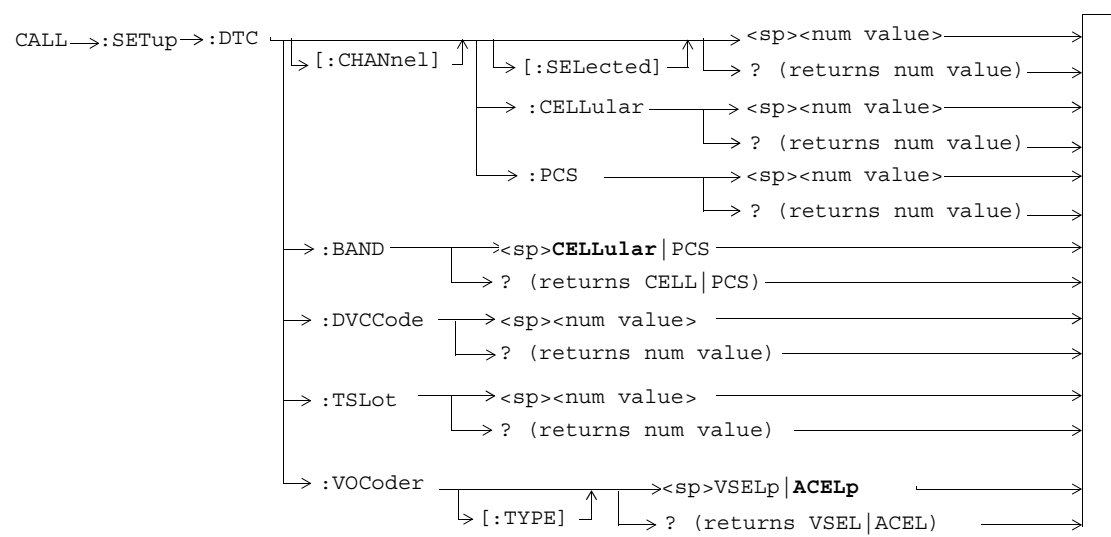

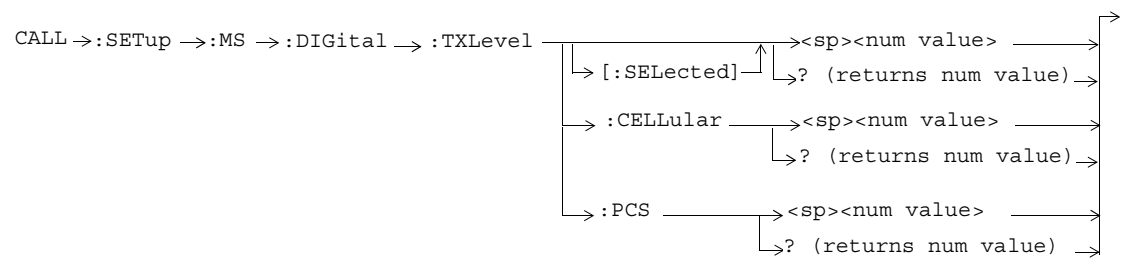
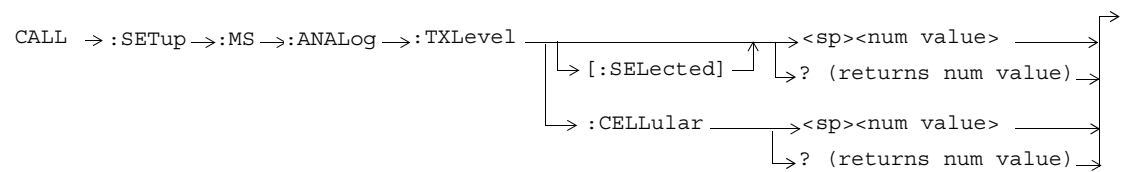

## CALL:SID

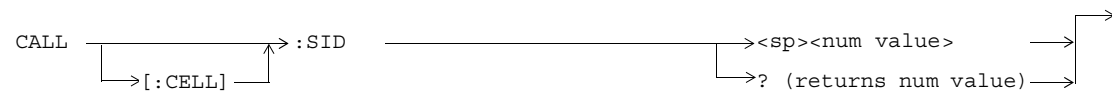

### CALL:SOCode



## CALL:STATUS

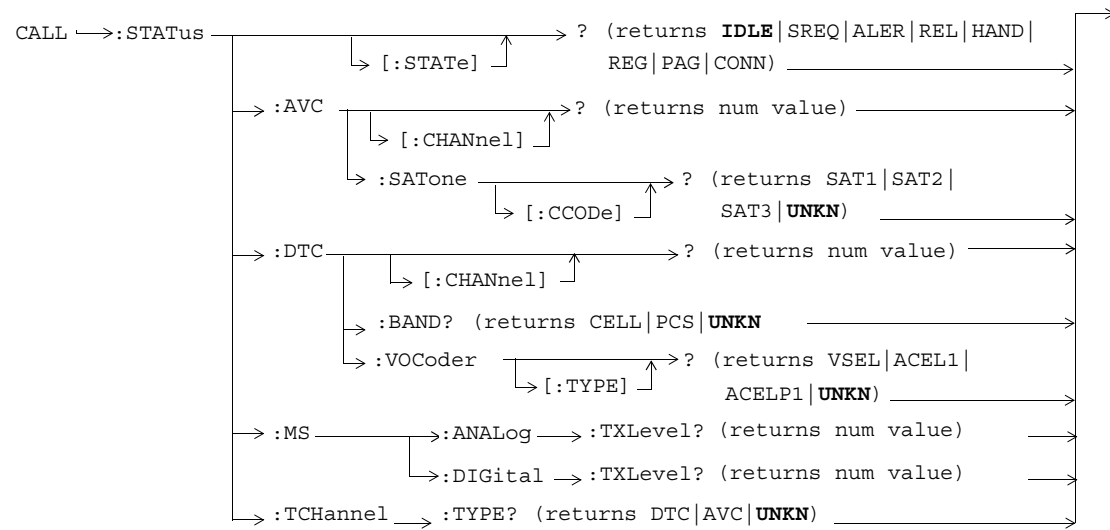

### **CALL:TCHannel**

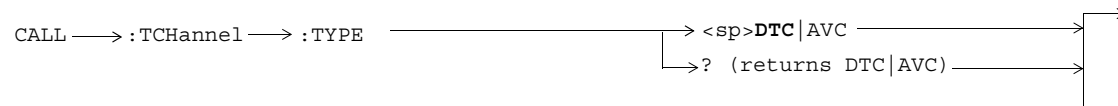

## DISPlay

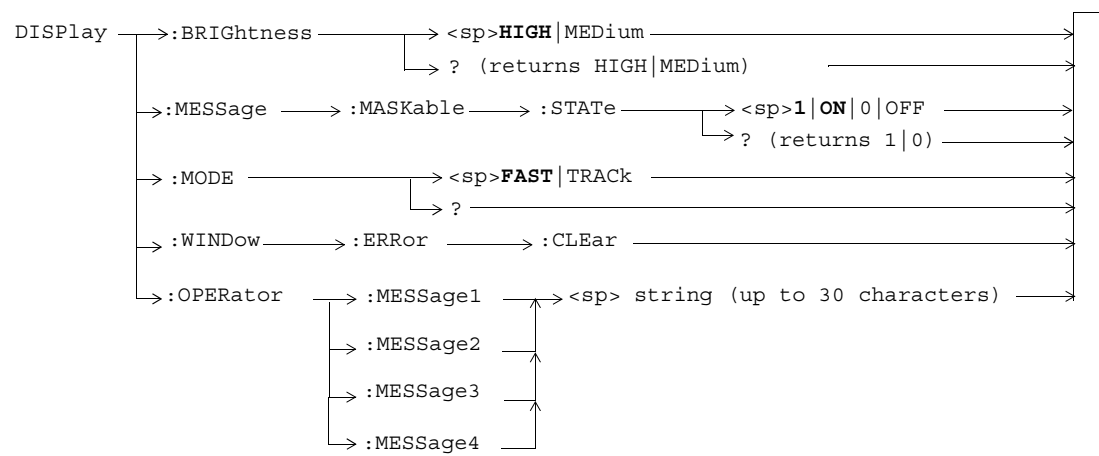

### FETCH:ACPower

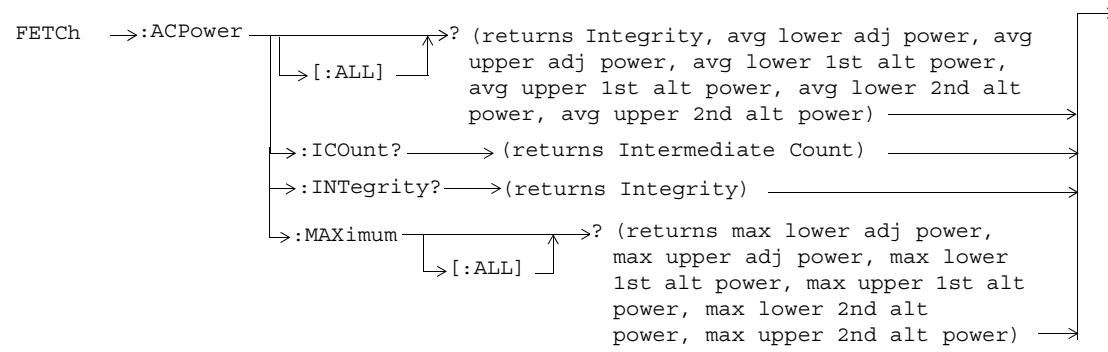



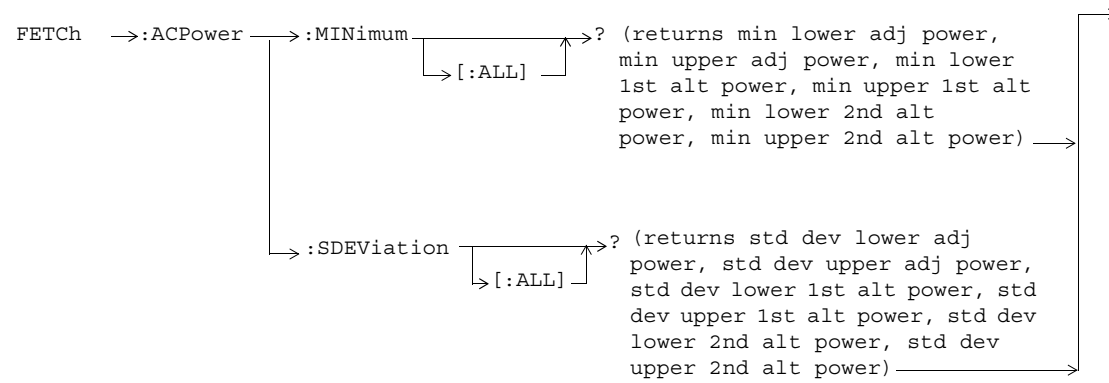

## **FETCh:AFANalyzer**

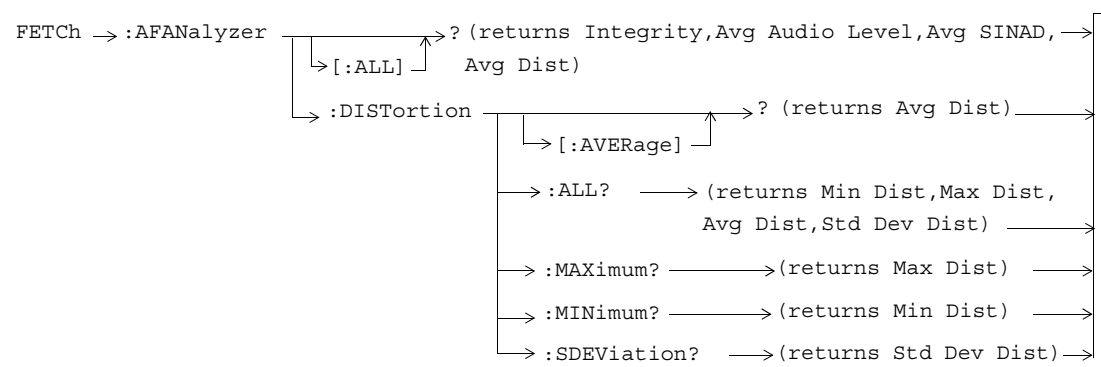

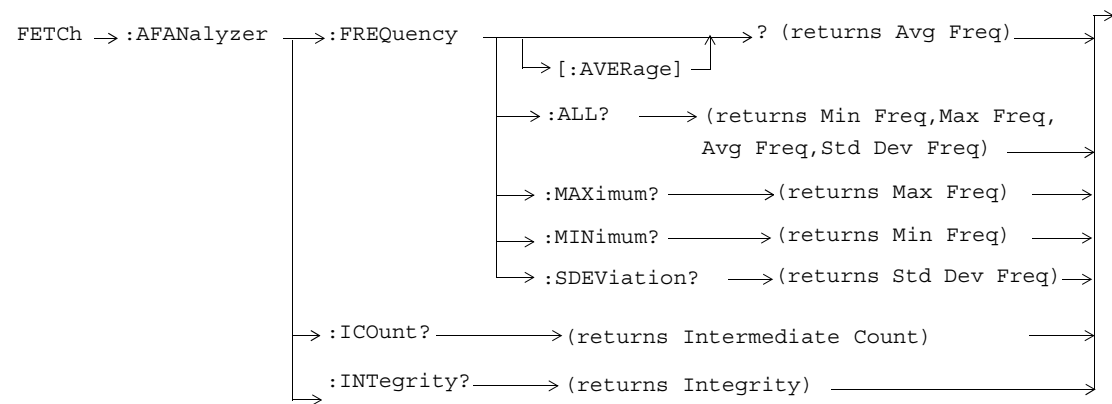

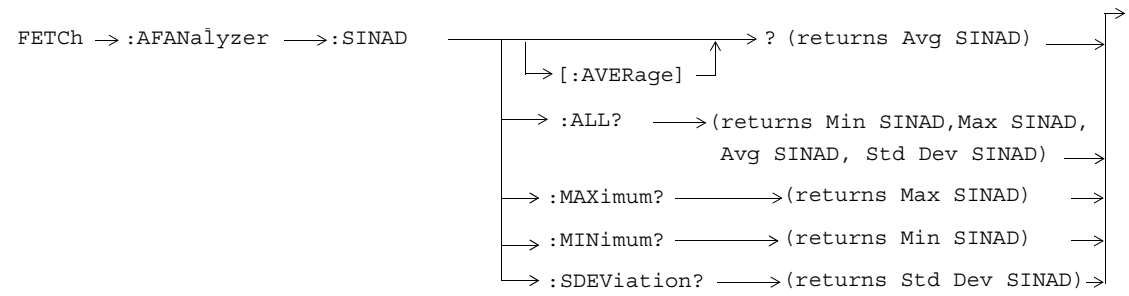

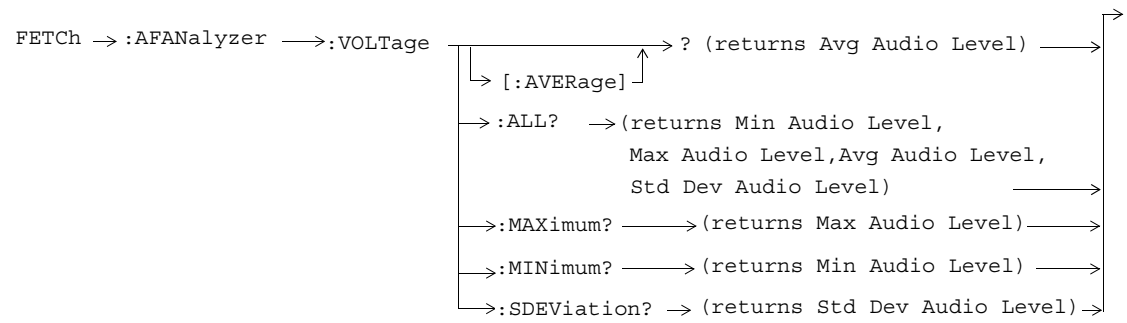

## FETCH:ATXPower

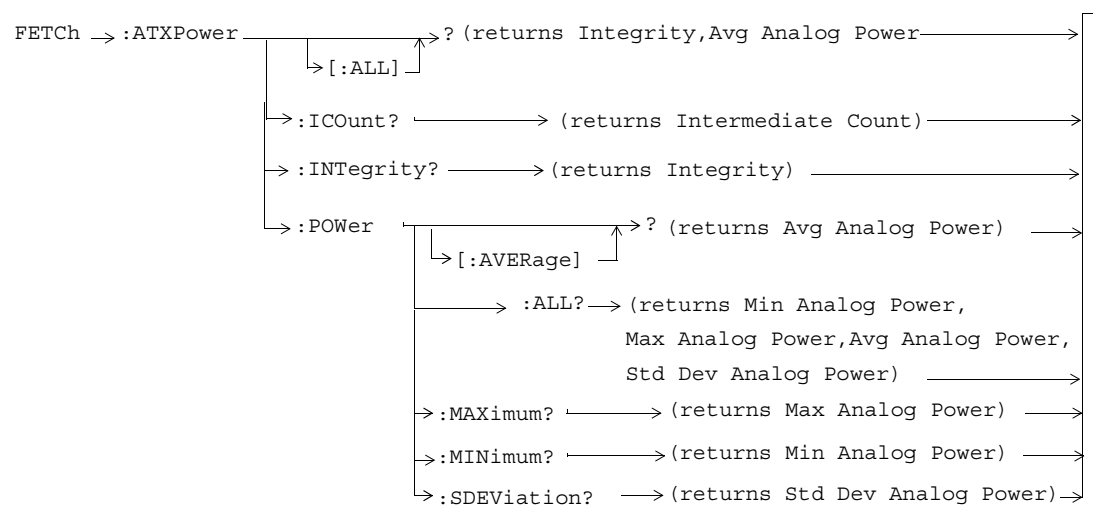

## FETCH:DPOWER

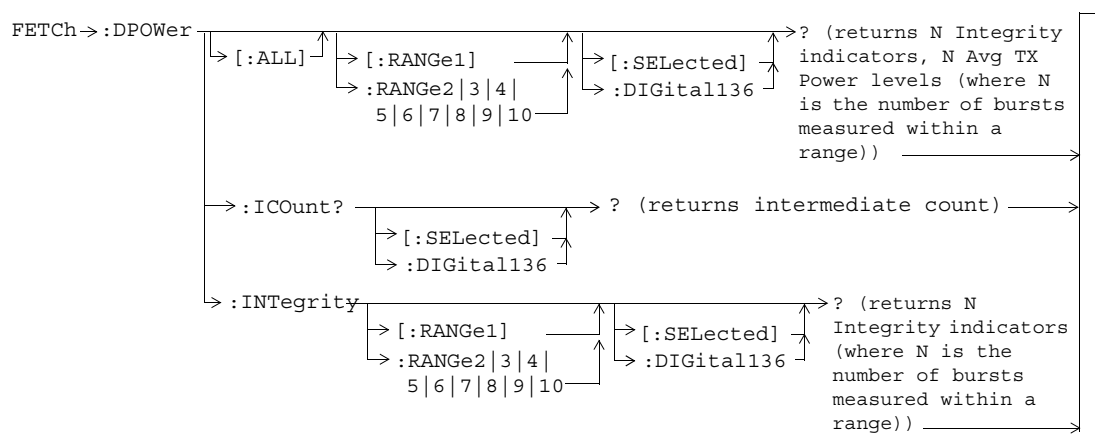

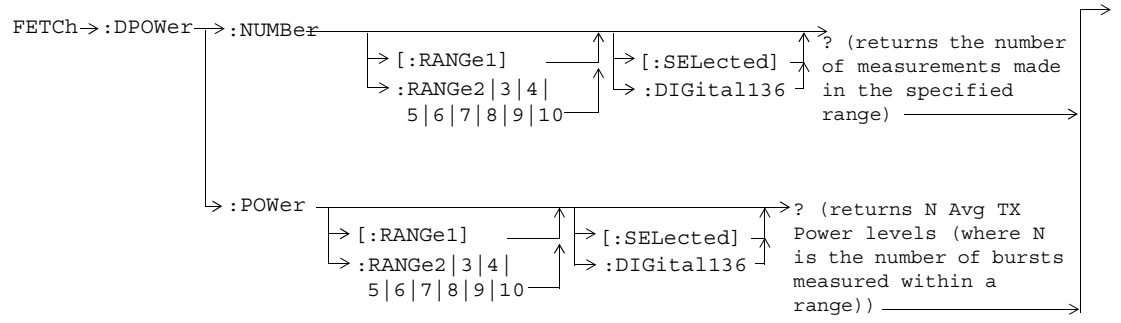



## FETCH:DTXPower

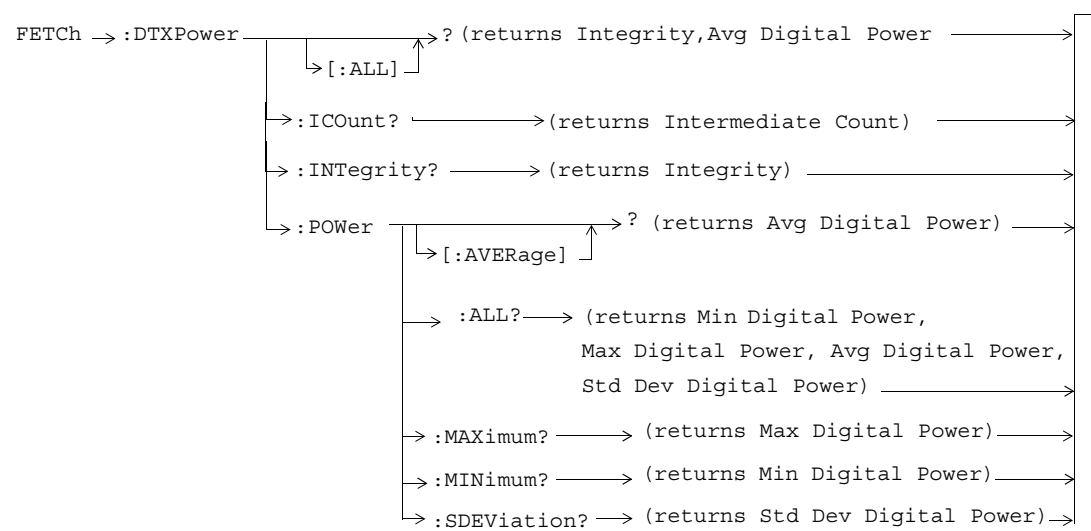

## **FETCh:FM**

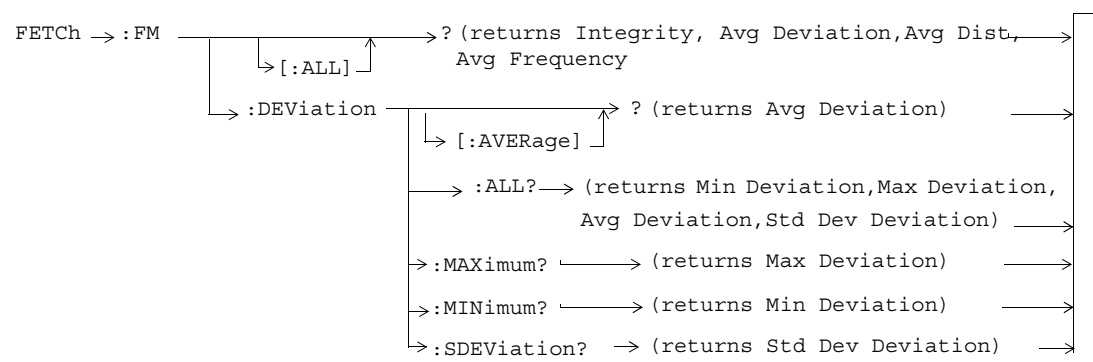

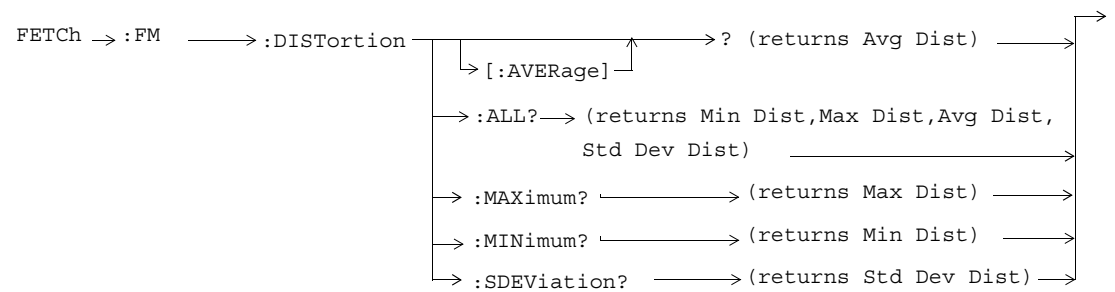

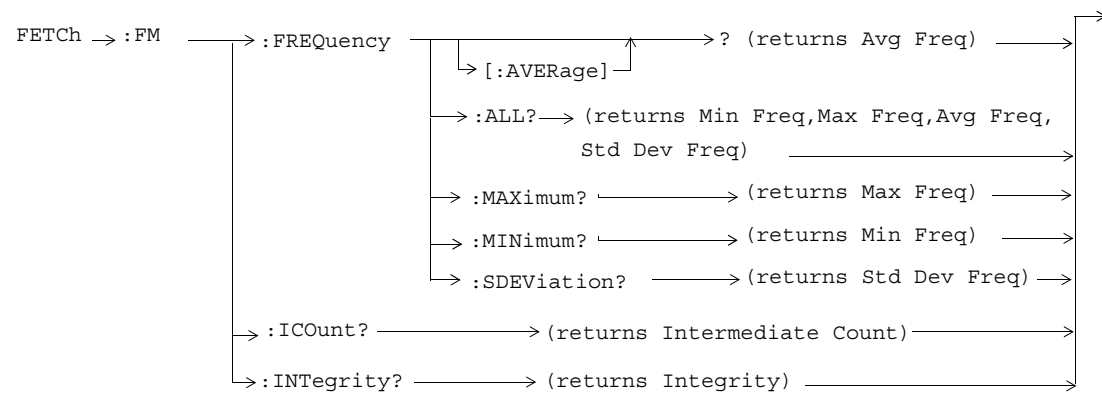

## FETCH:FSTability

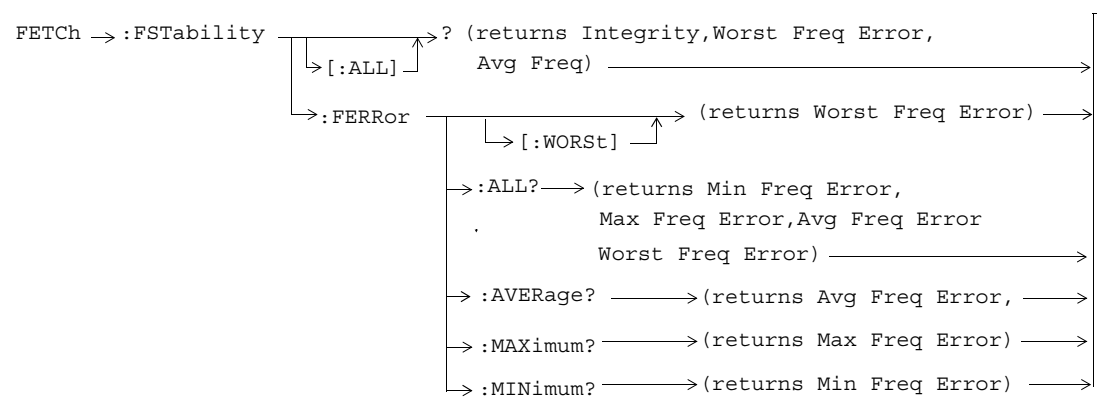

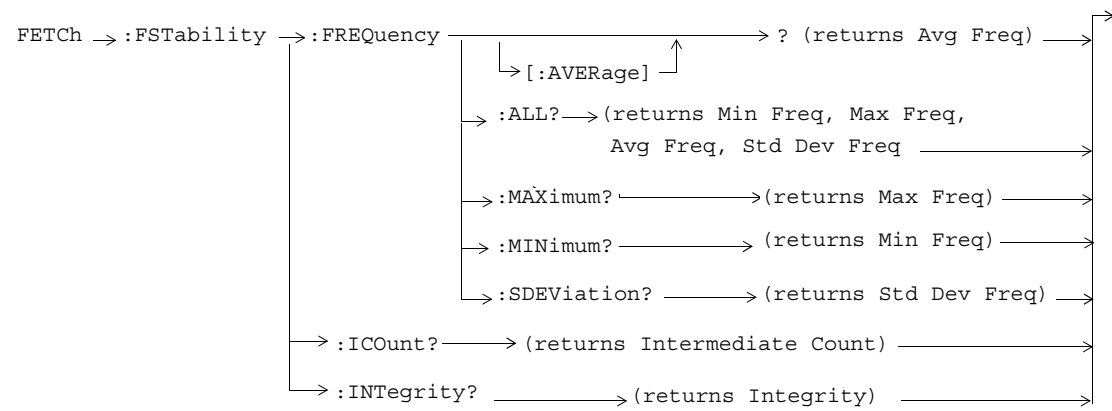

### **FETCH:IQTuning**

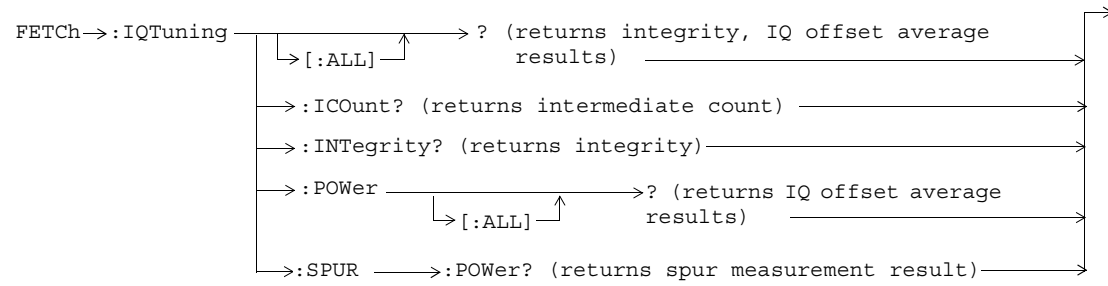

### **FETCH:LBError**

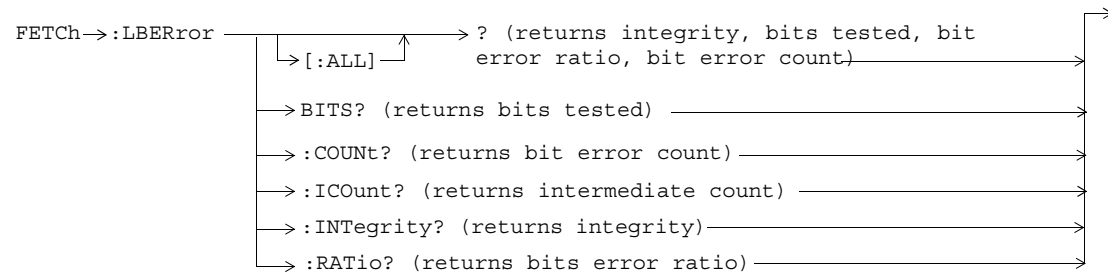



## FETCH:MACCuracy

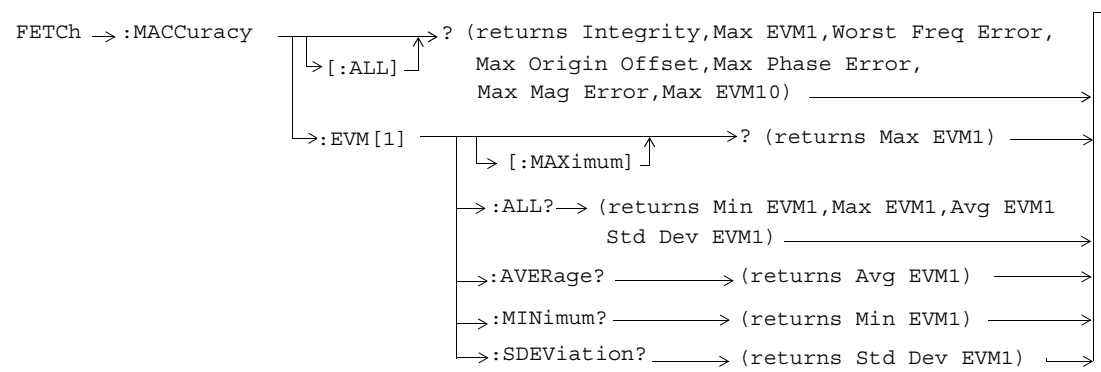

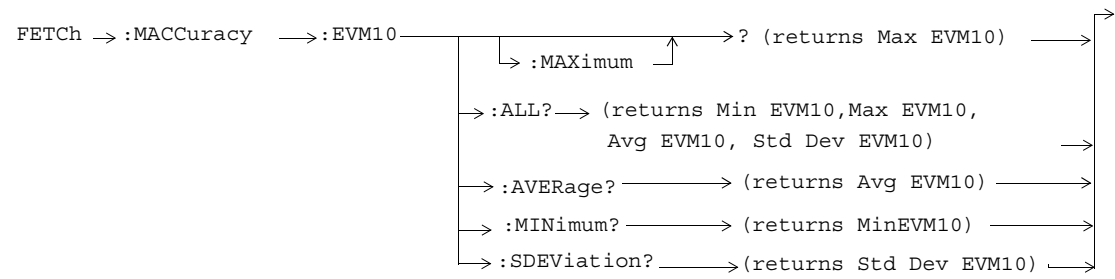

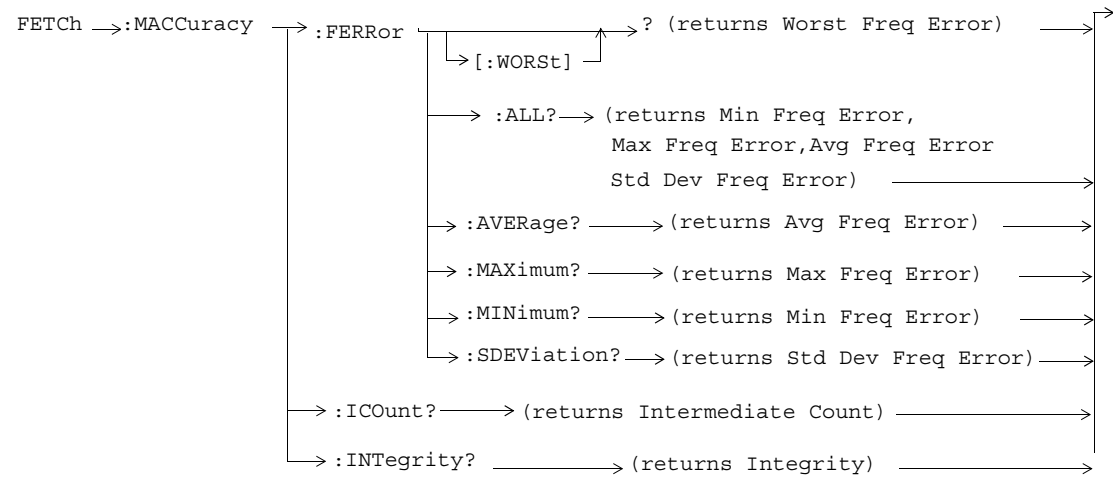

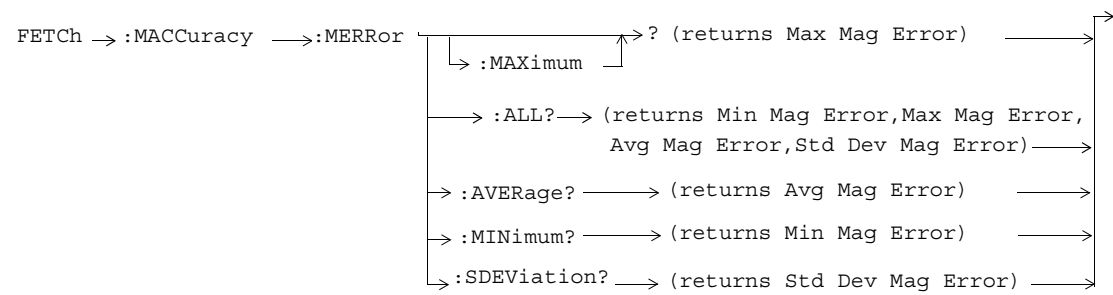

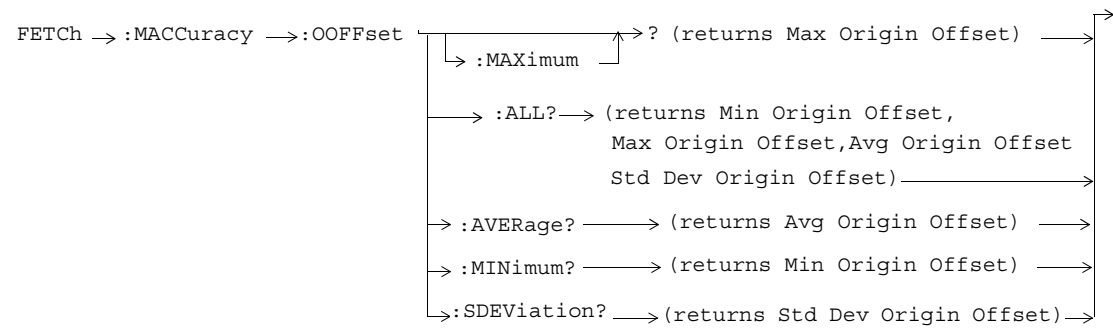

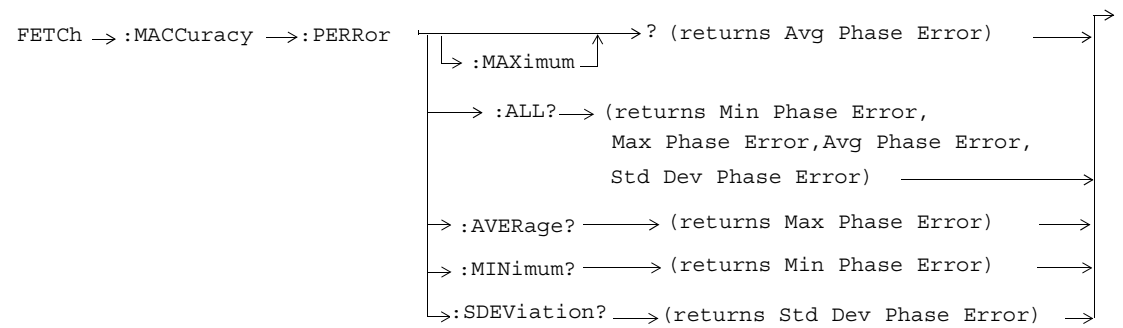

## INITiate

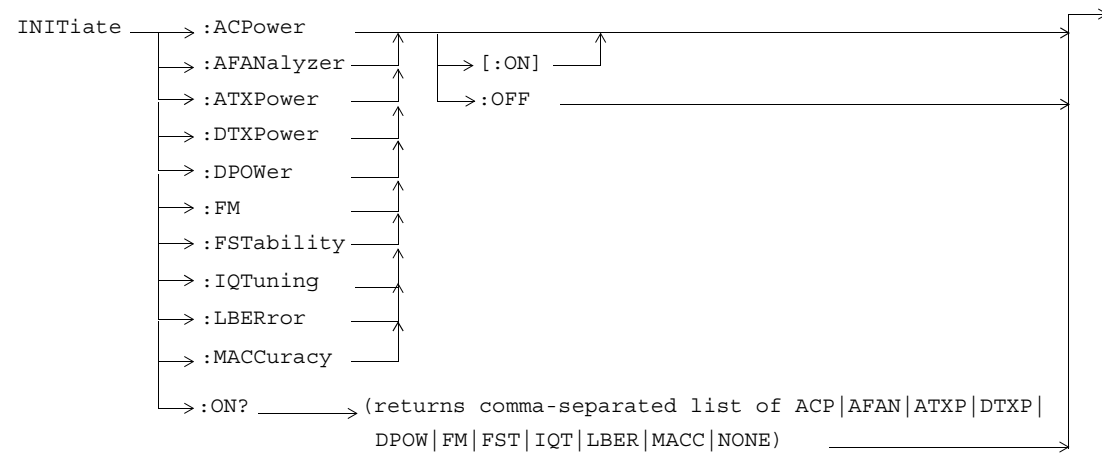

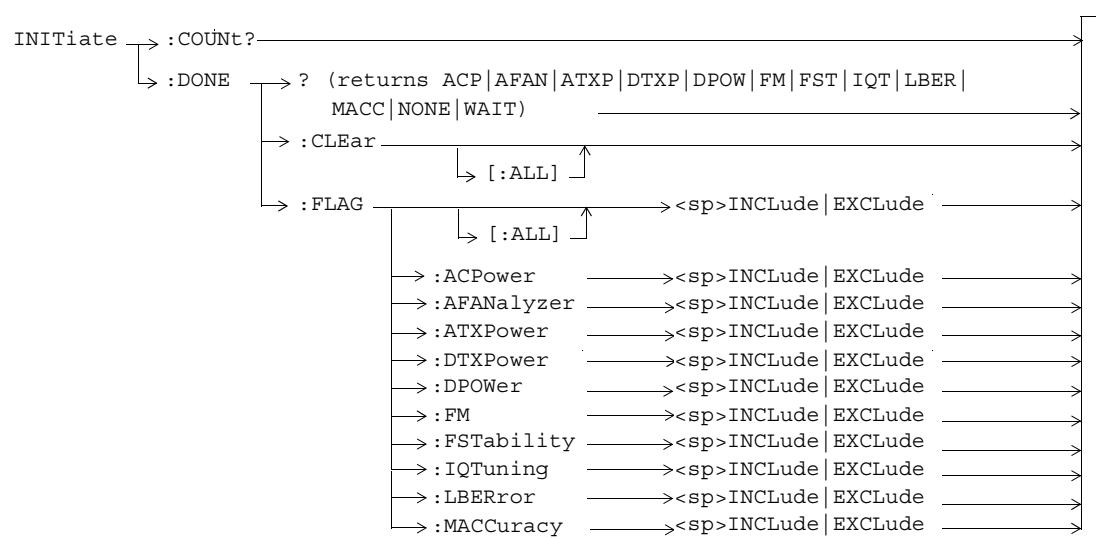



## READ

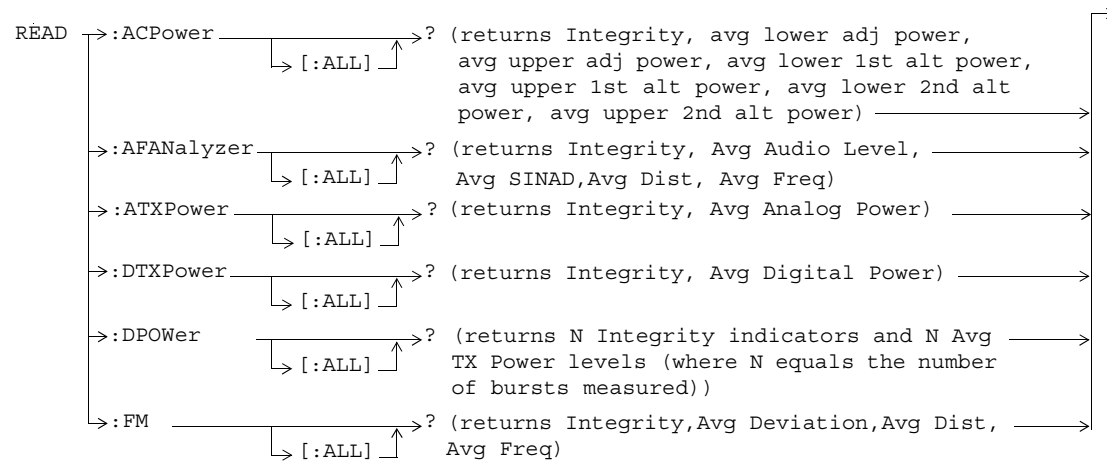

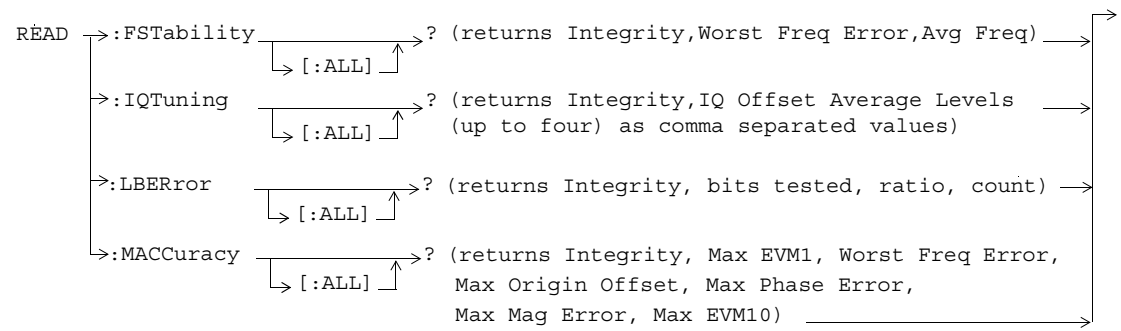

## RFAnalyzer

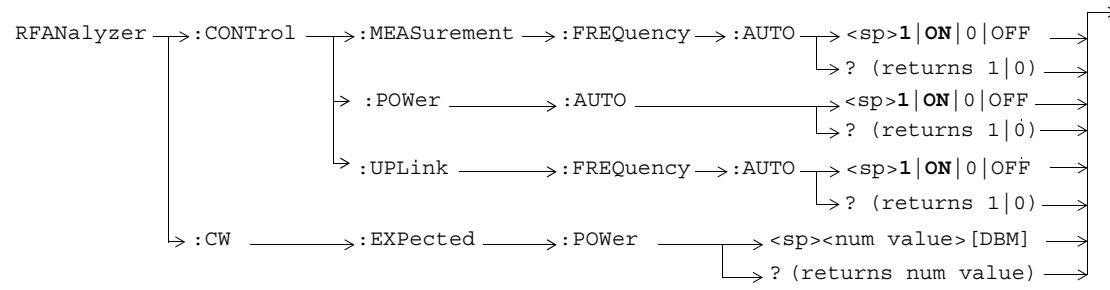

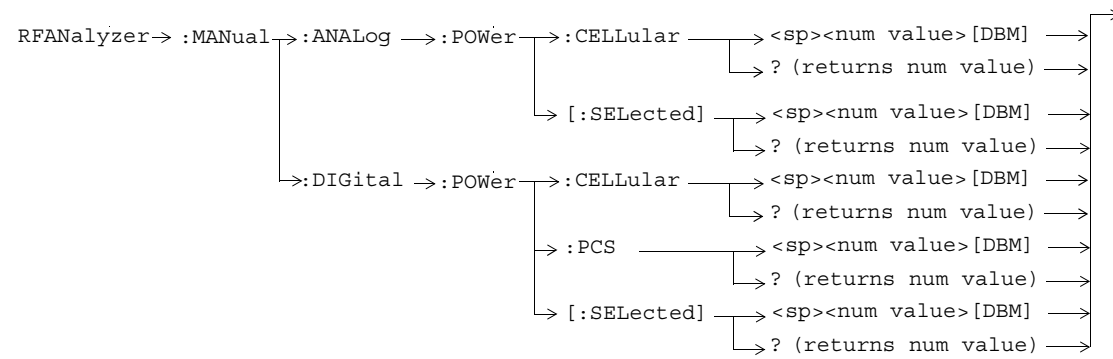

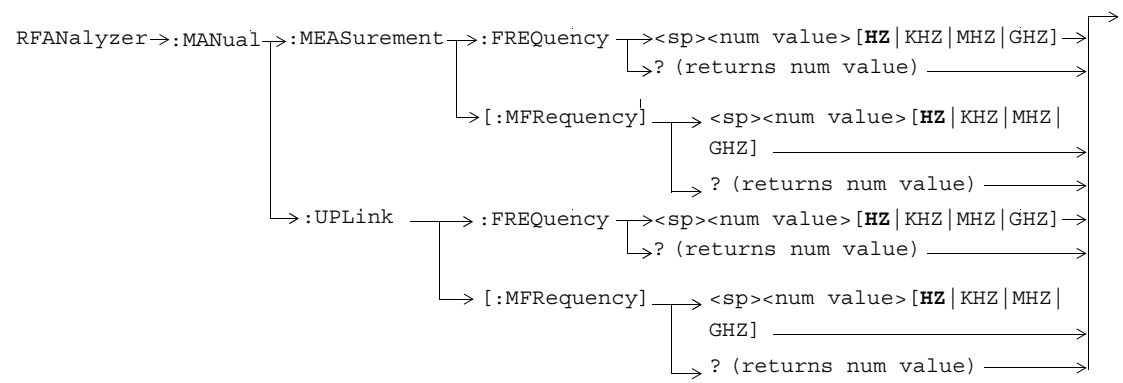

### SETup[:ALL]:CONTInuous



### SETup:ACPower

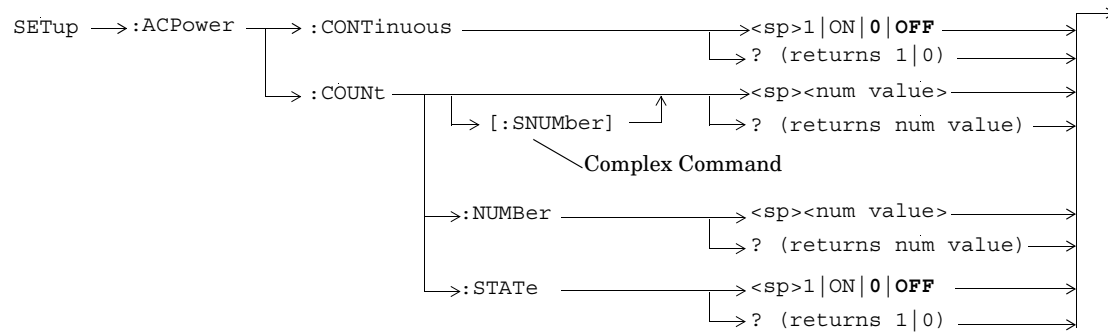

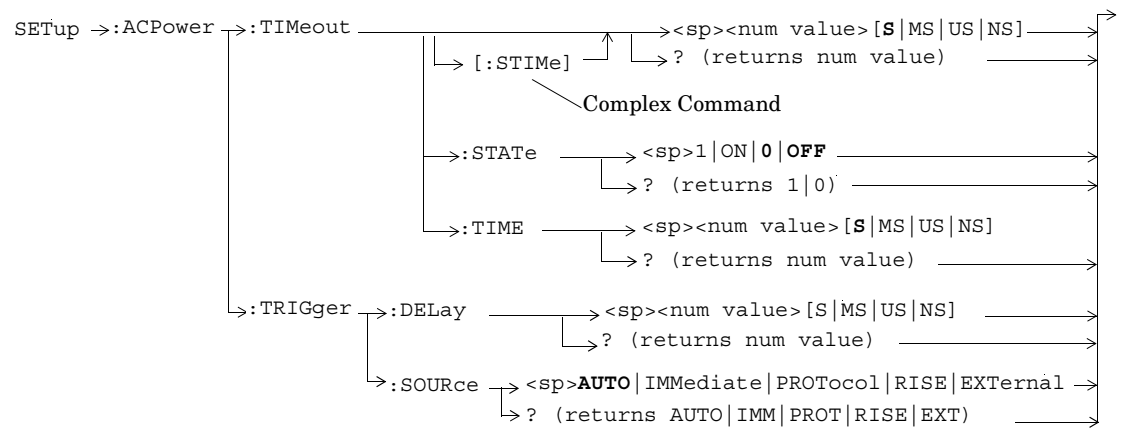



## SETup:AFANalyzer

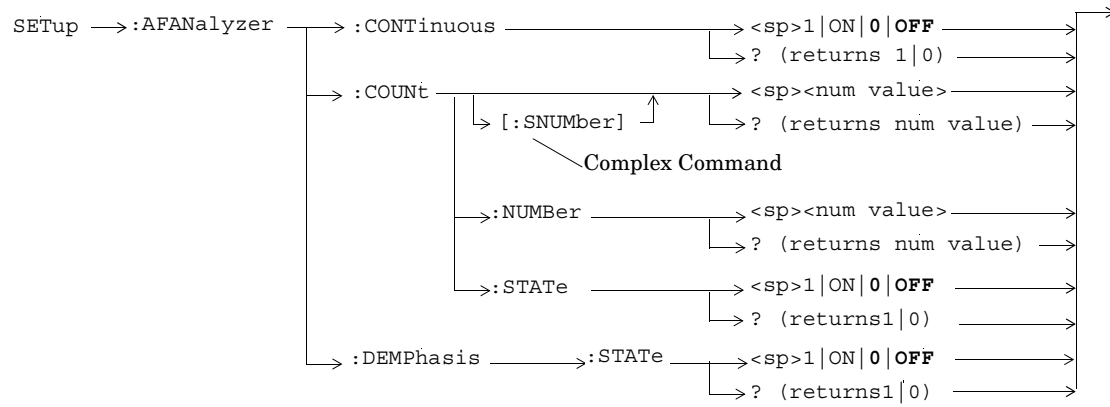

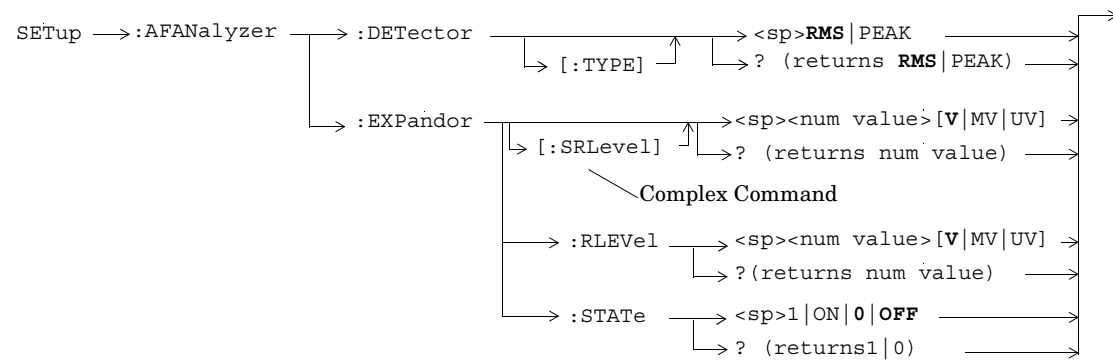

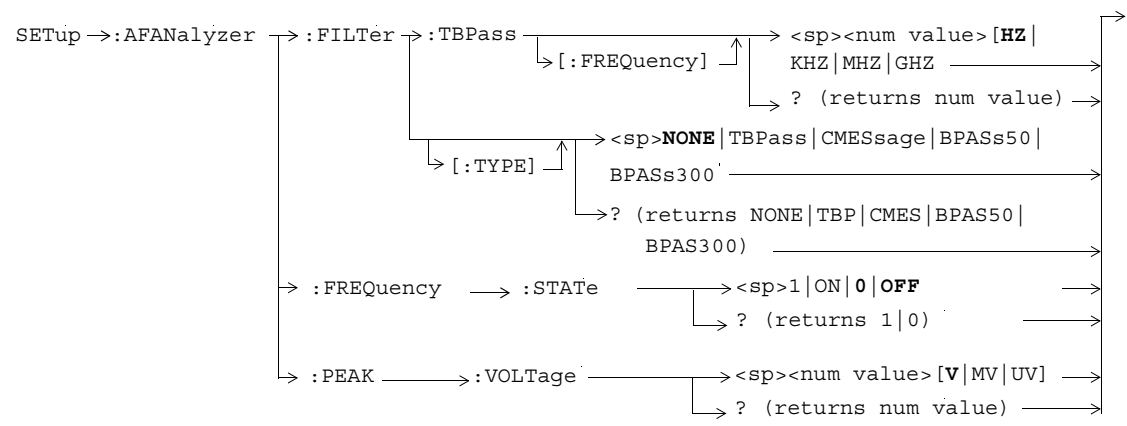

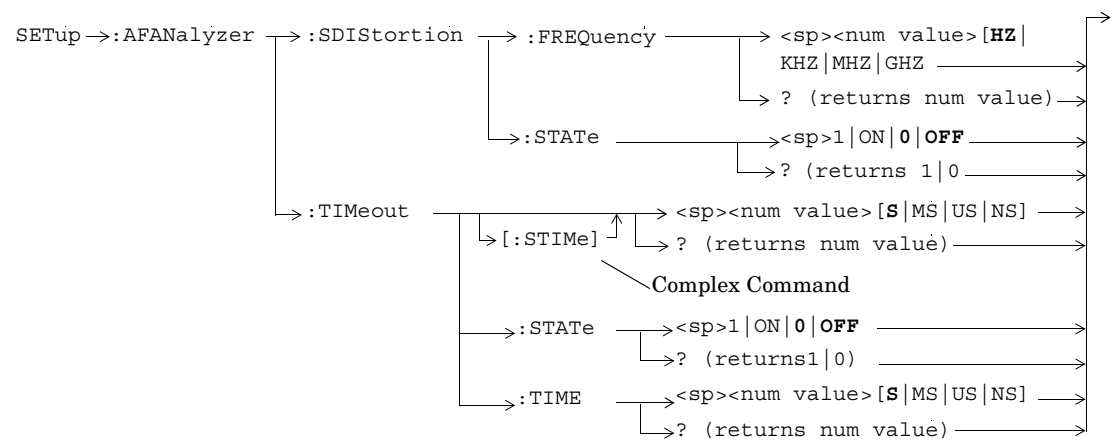

## SETup:ATXPower

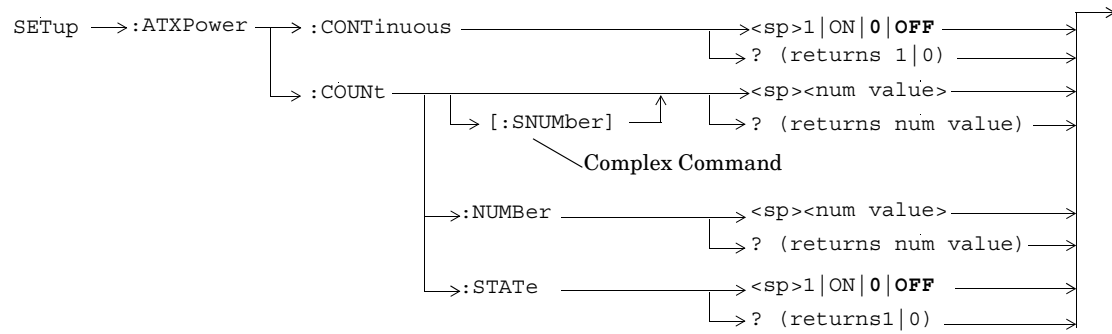

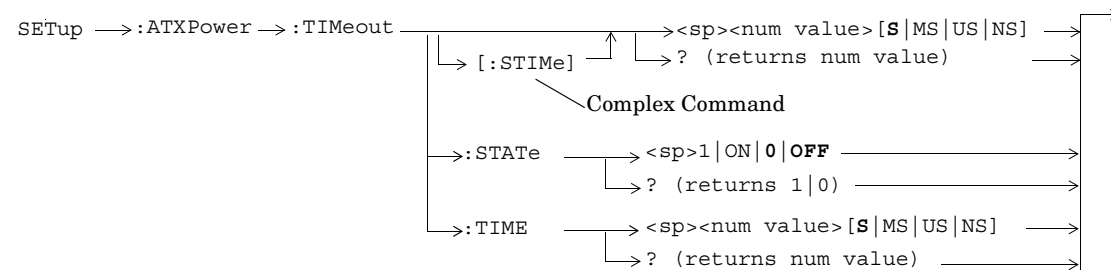

## SETup:DPOWER

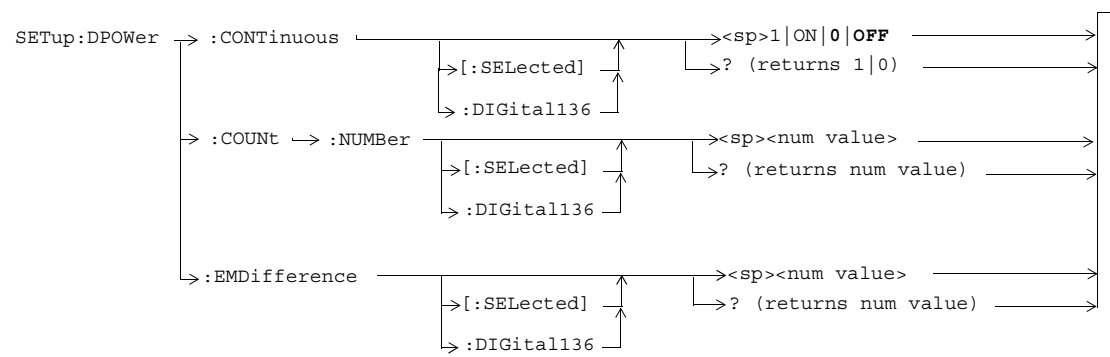

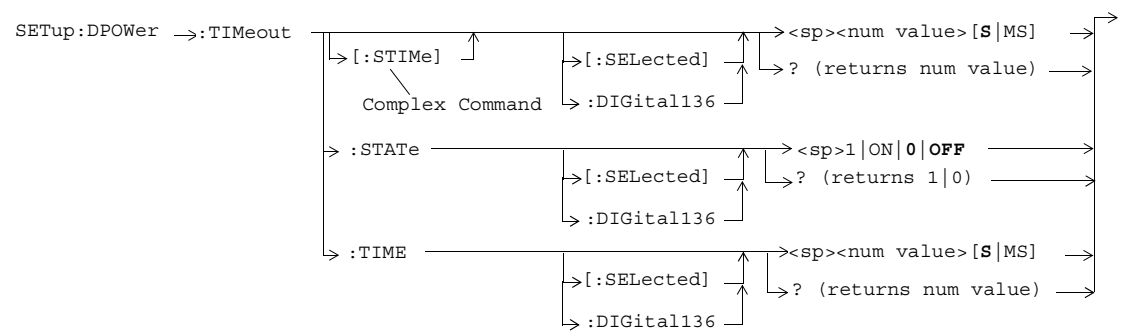



## SETup:DTXPower

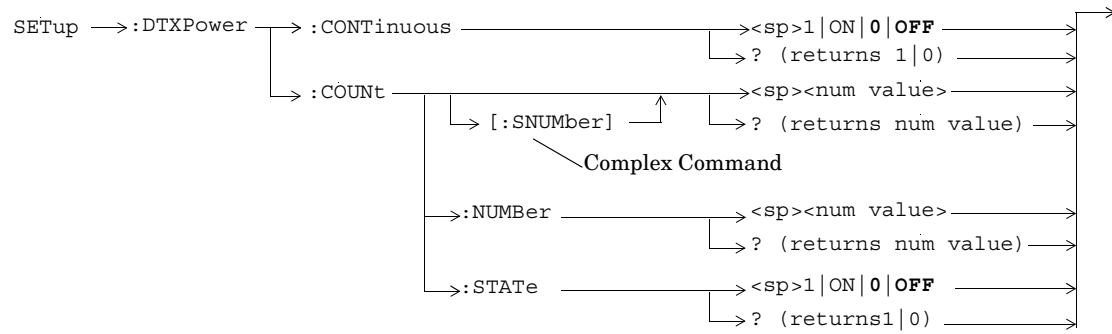

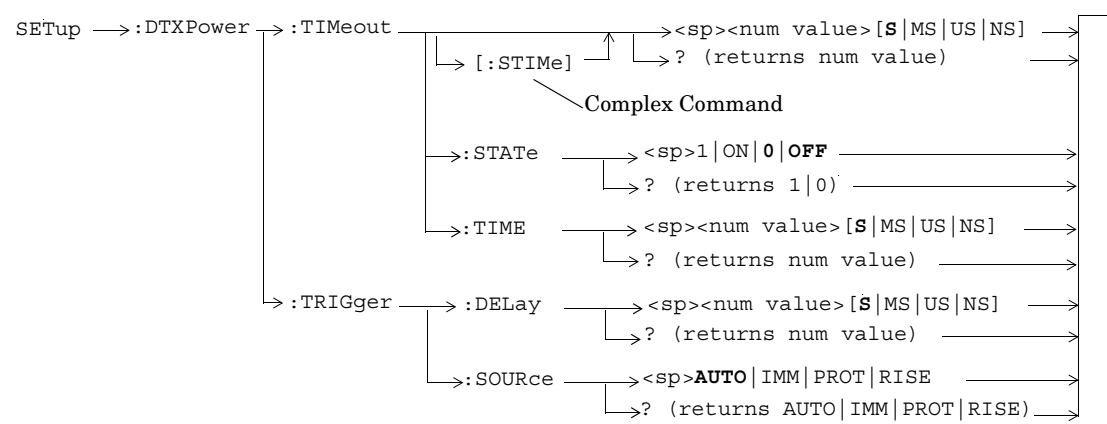

## SETup:FM

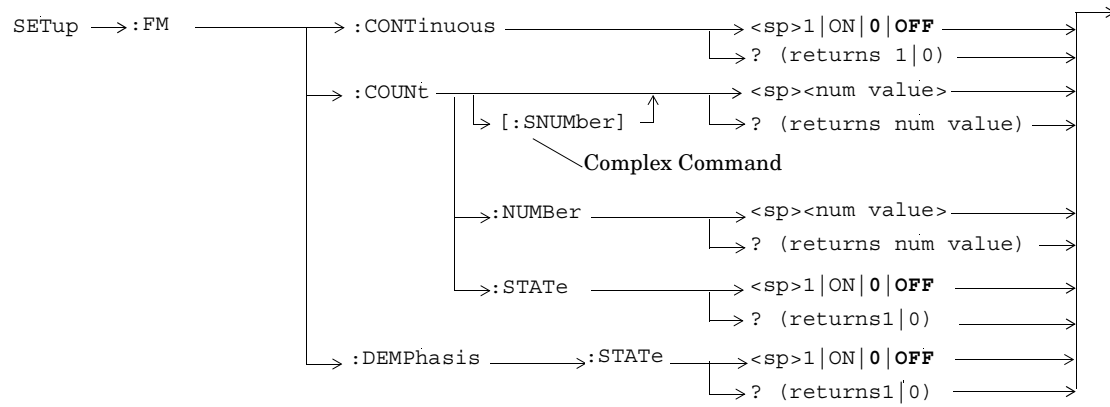

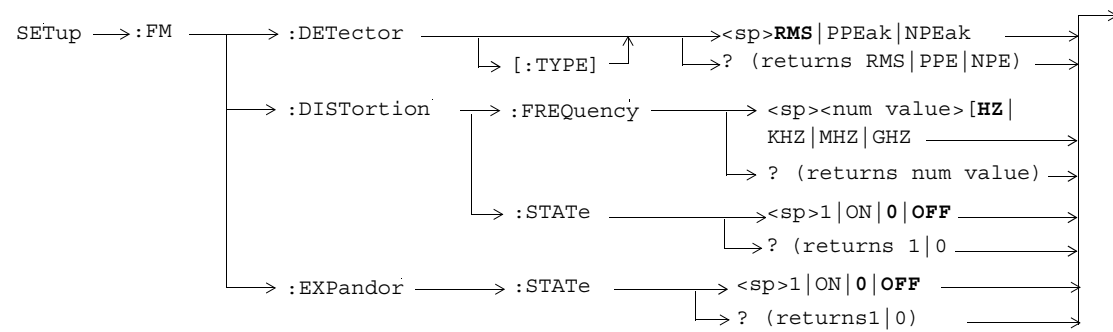

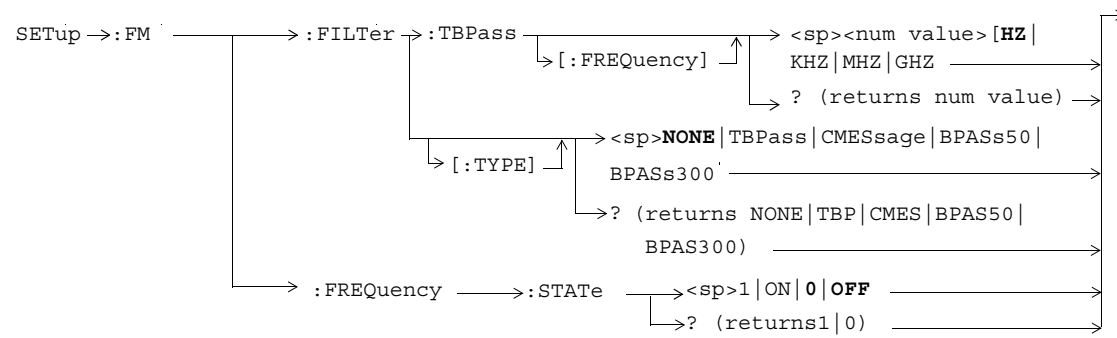

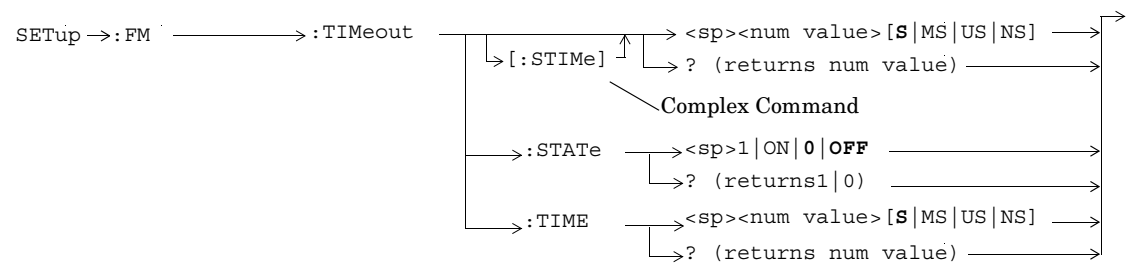

### SETup:FSTability

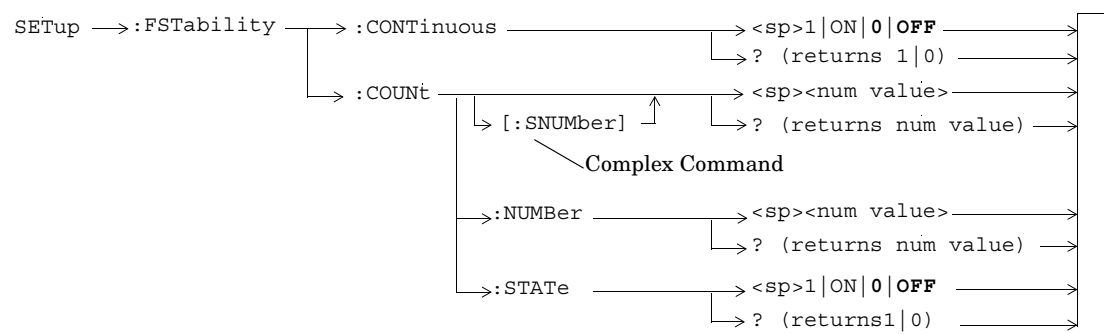

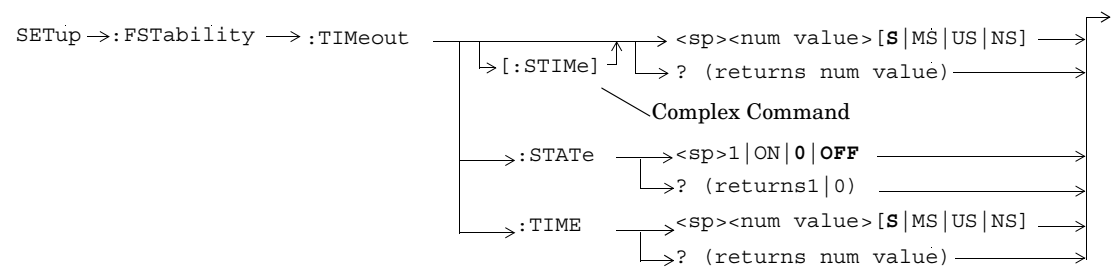



## SETup:IQTuning

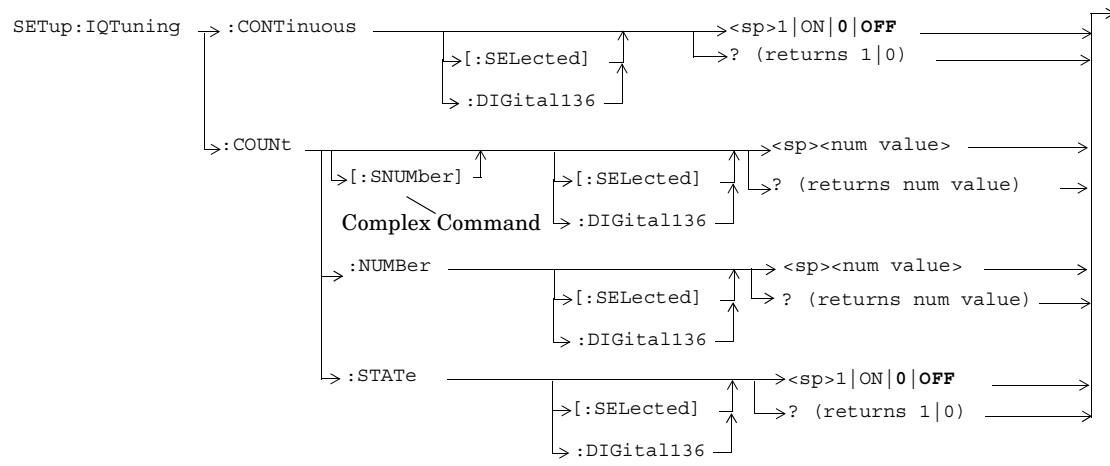

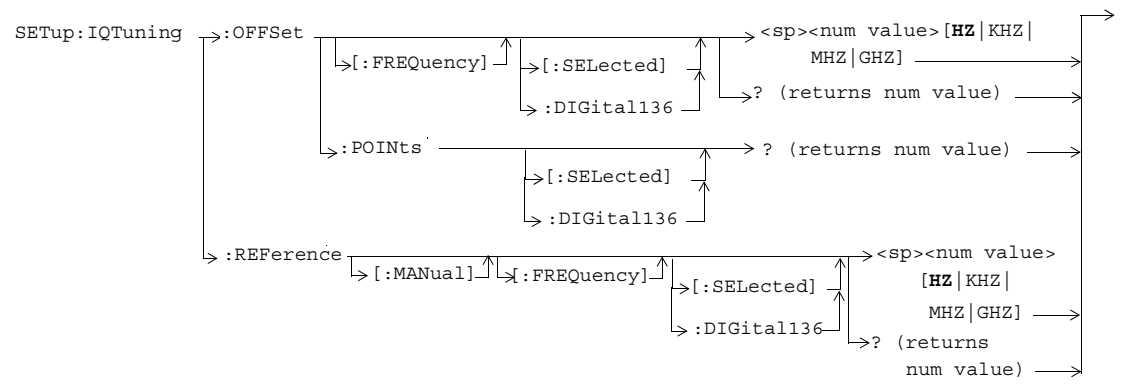

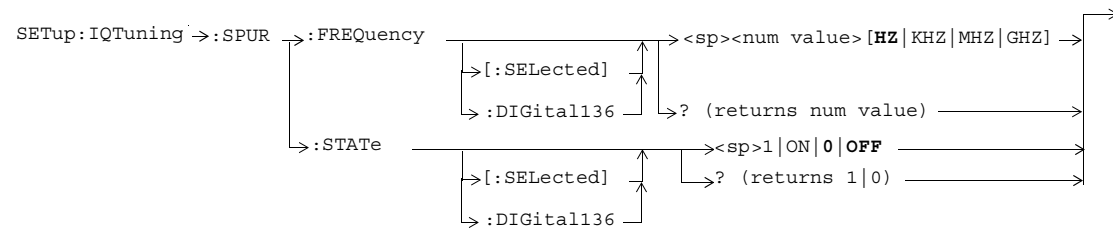

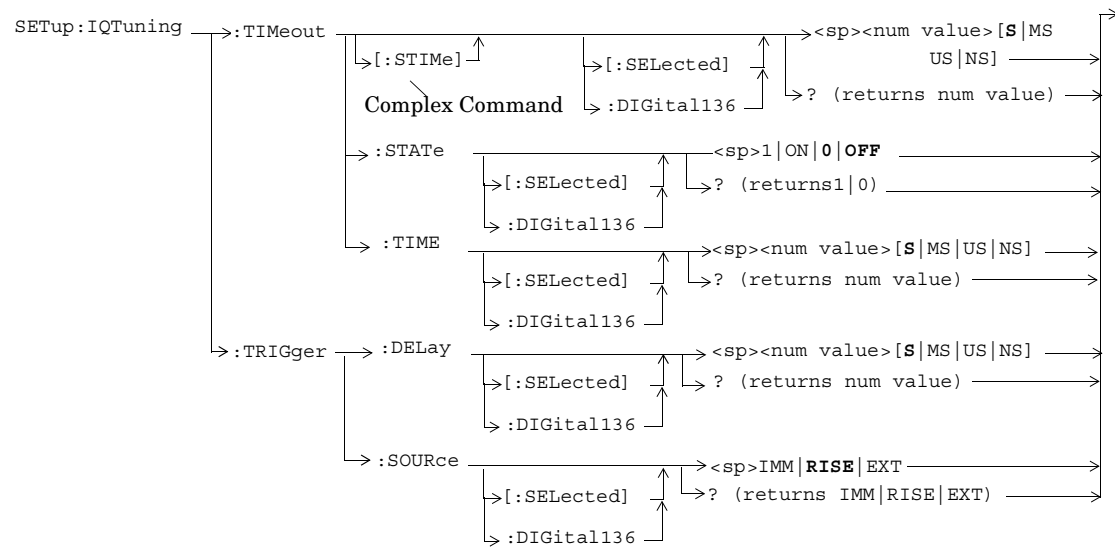

## SETup:LBError

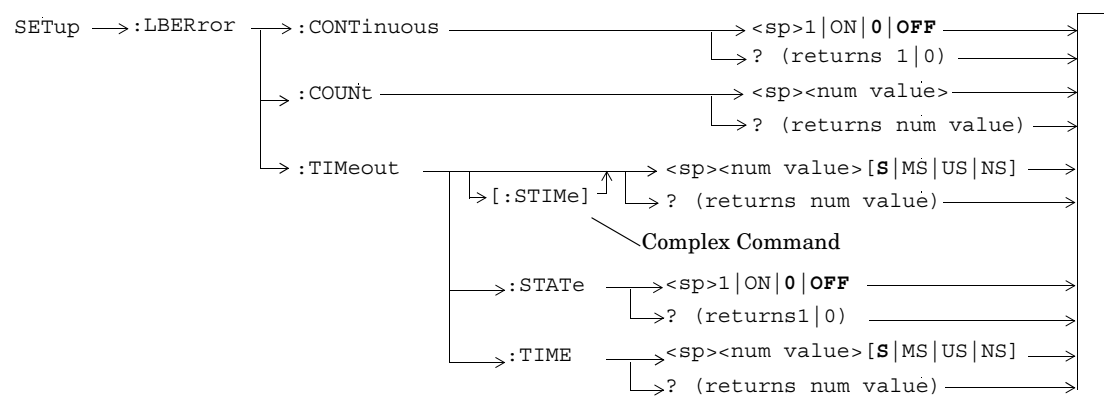

## SETup:MACCuracy

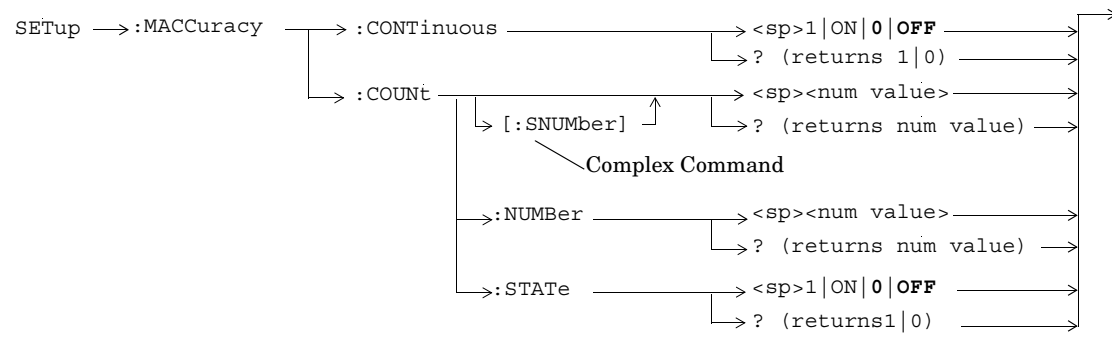

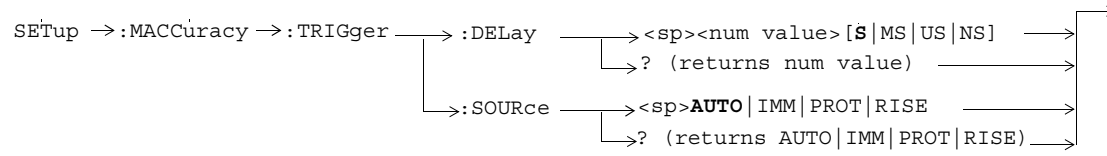
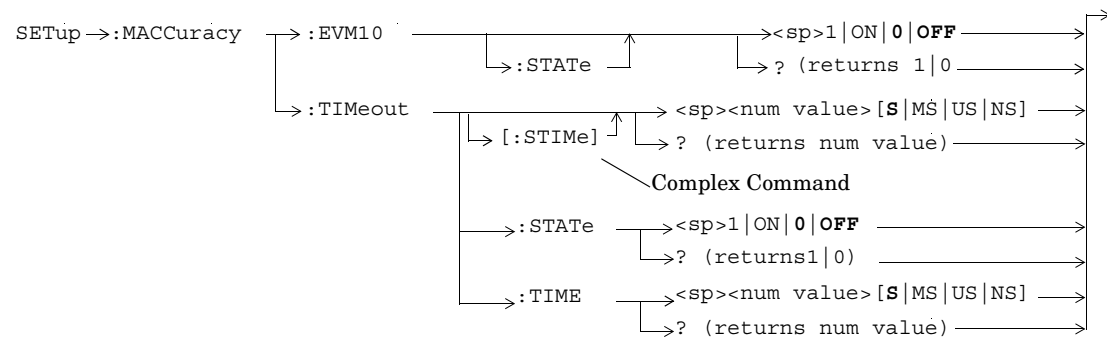

## STATUS:OPERation

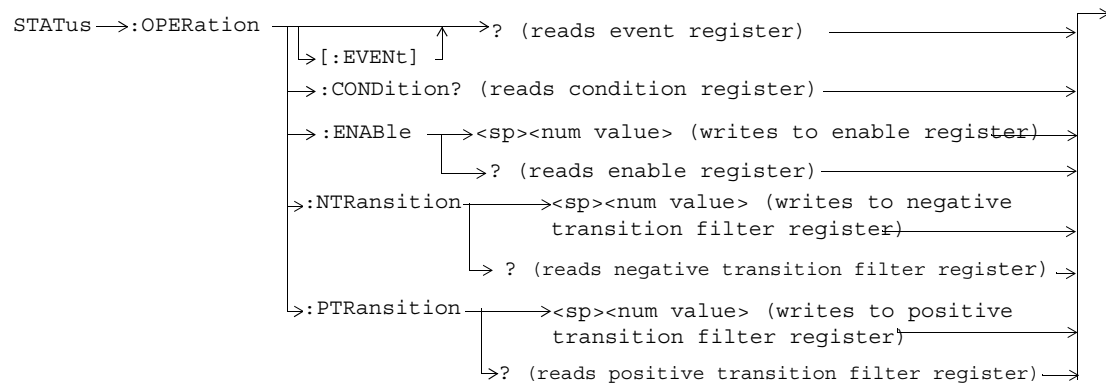



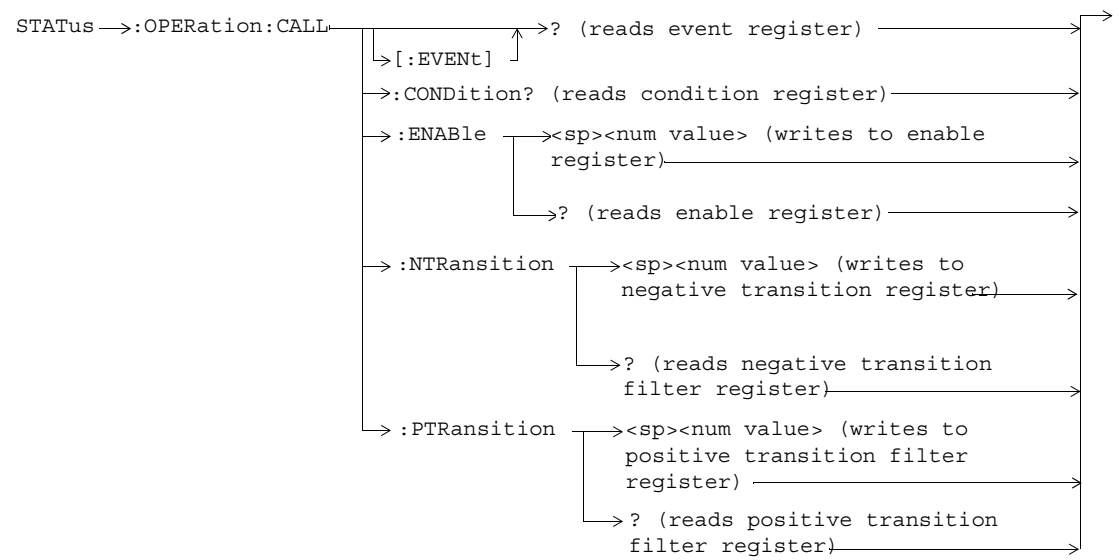

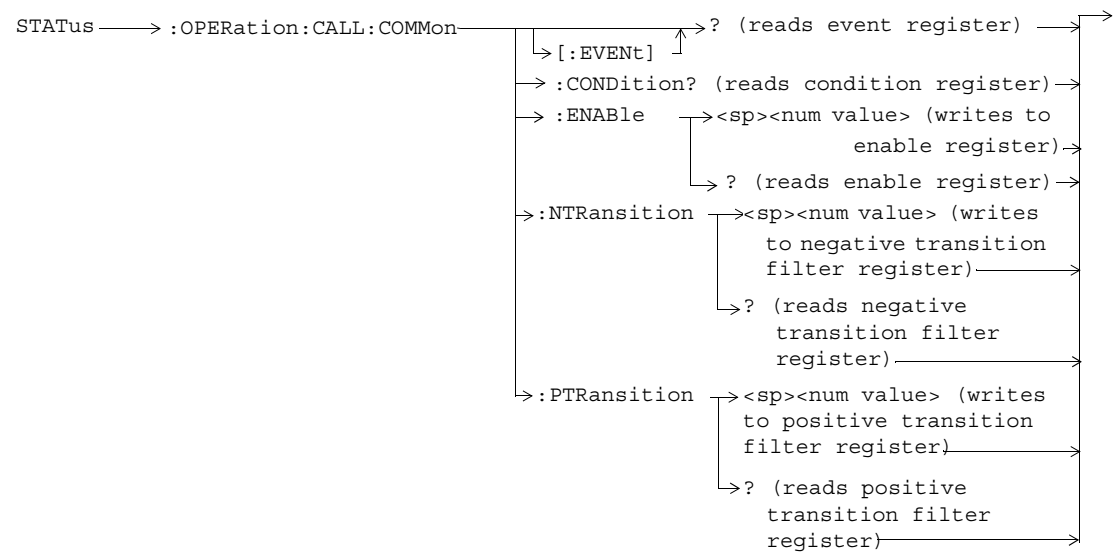

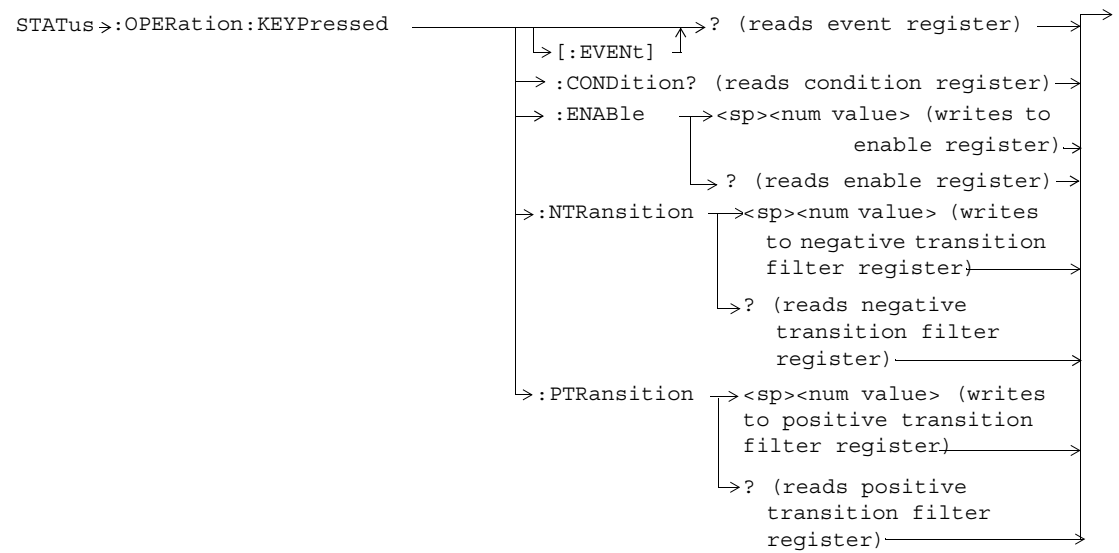

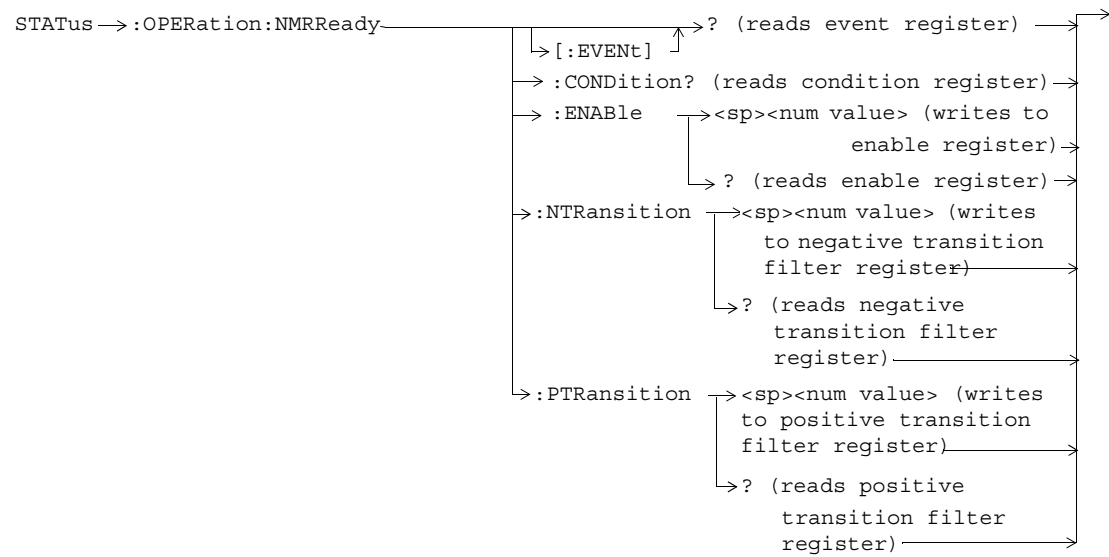

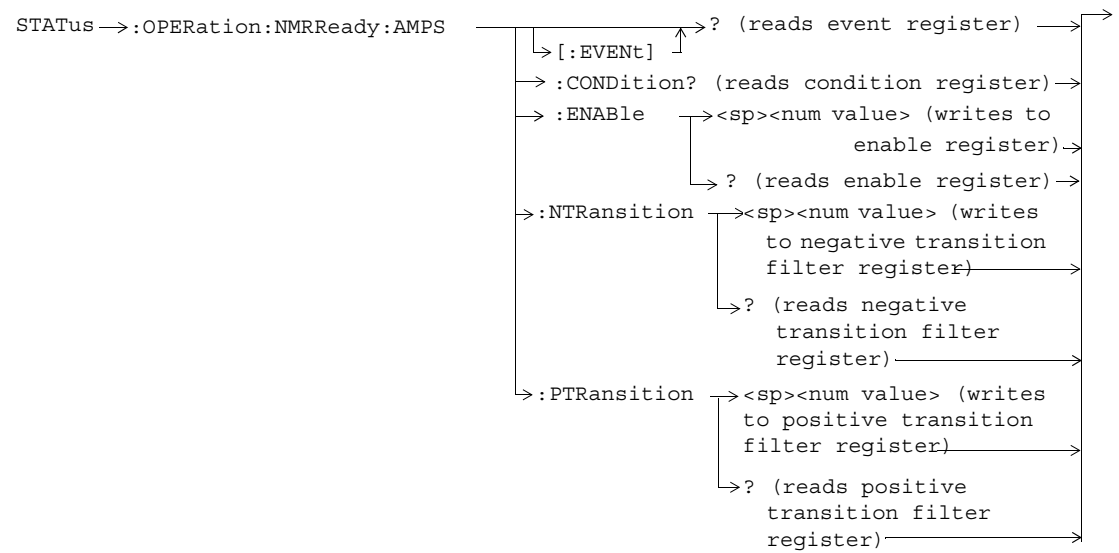

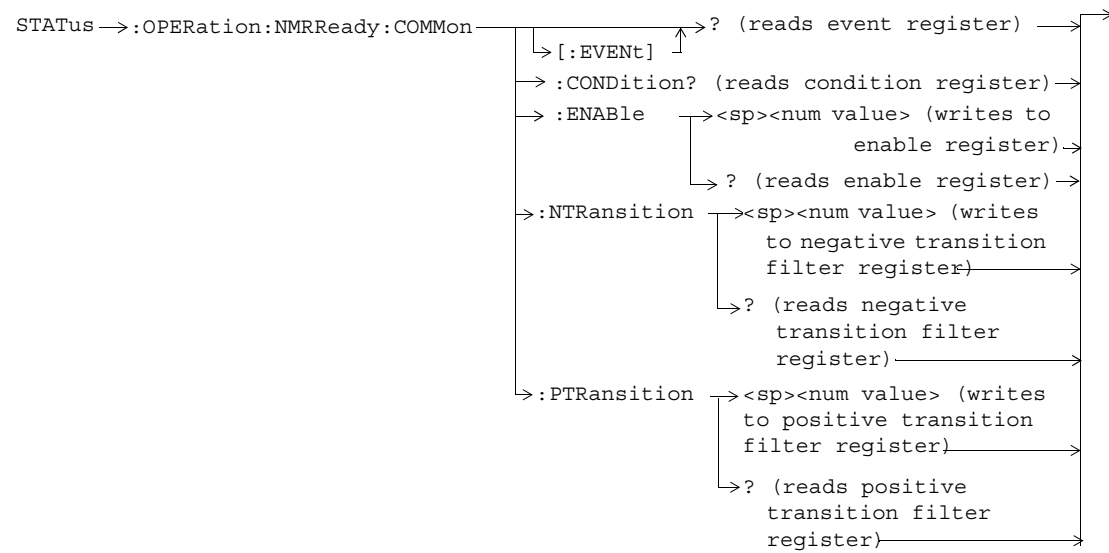

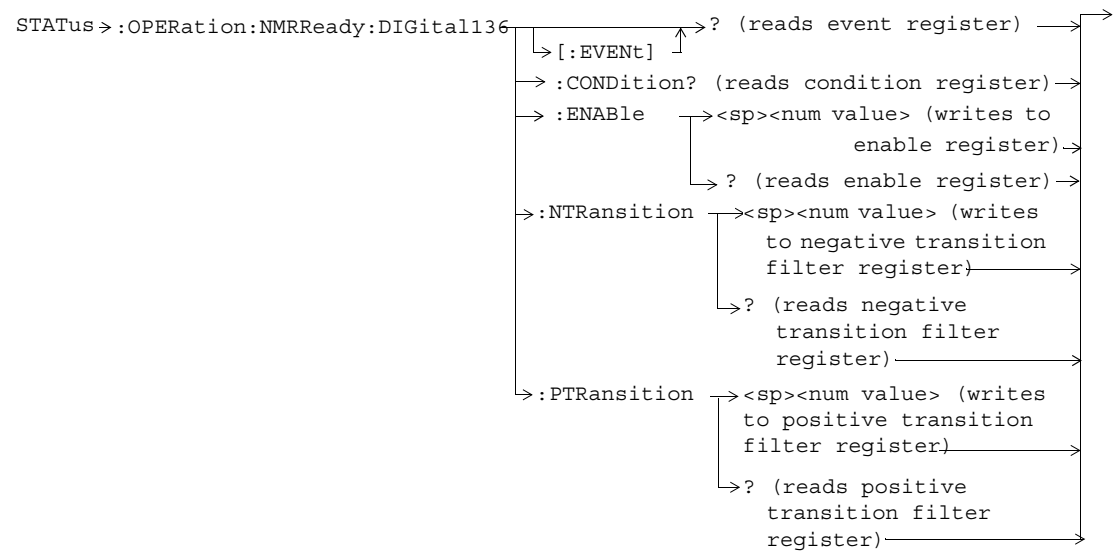

## STATUS:PRESet

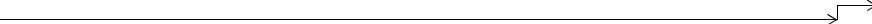
STATUS → :PRESet 

“Diagram Conventions” on page 7

### STATUS:PRESet

Function	Preset the Status Subsystem Sets all Enable Registers to 0 (not enabled). Sets all Positive Transition Registers (PTR) to 1 (positive transitions enabled). Sets all Negative Transition Registers (NTR) to 0 (negative transitions disabled).
----------	---------------------------------------------------------------------------------------------------------------------------------------------------------------------------------------------------------------------------------------------------------



## STATUS:QUESTIONABLE

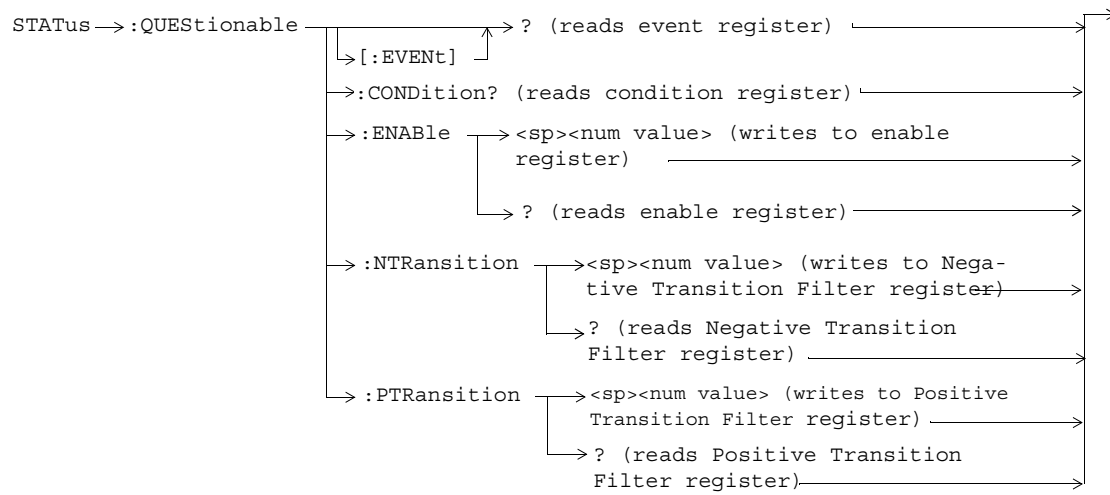

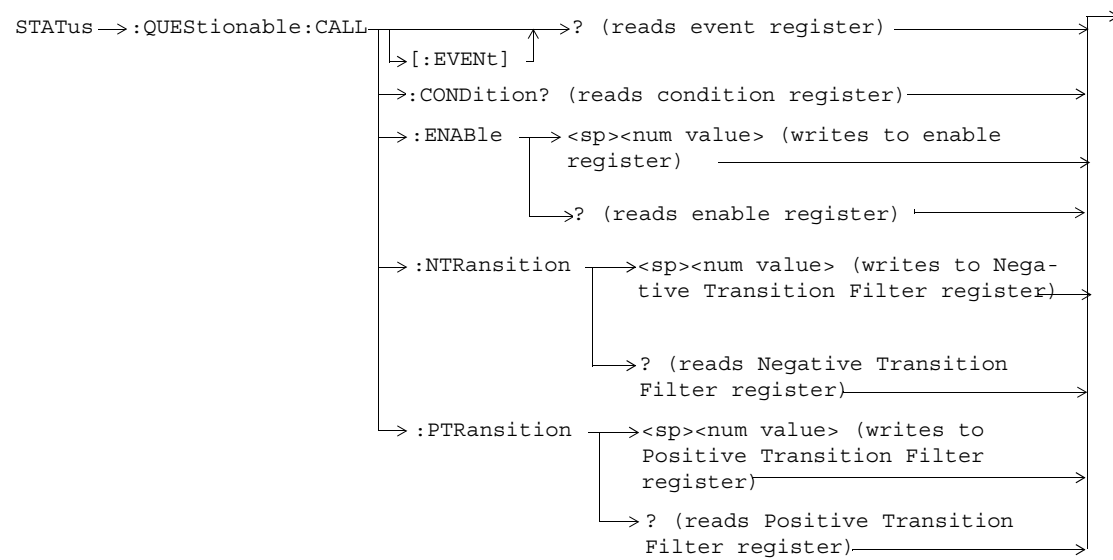

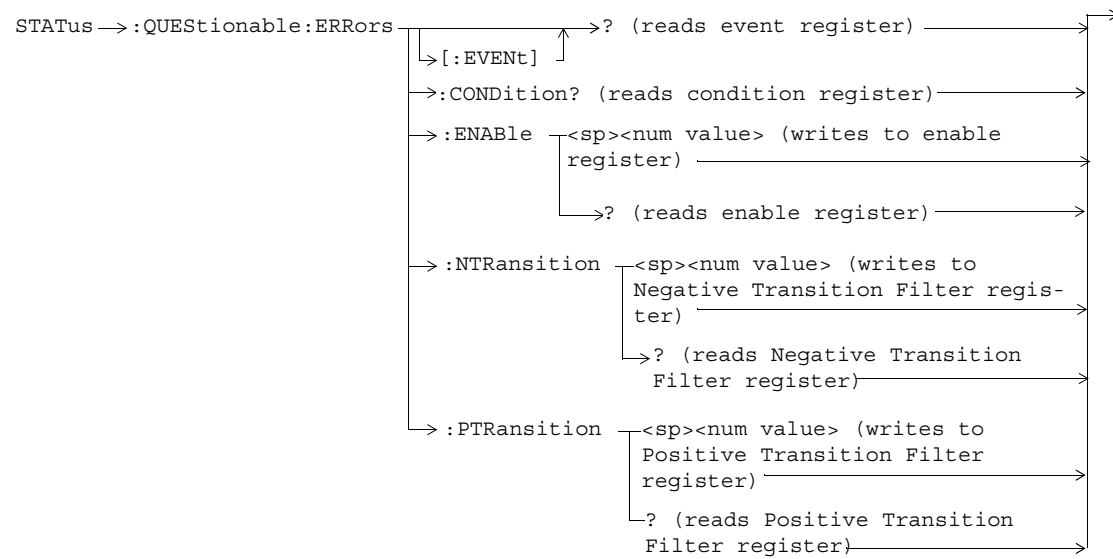

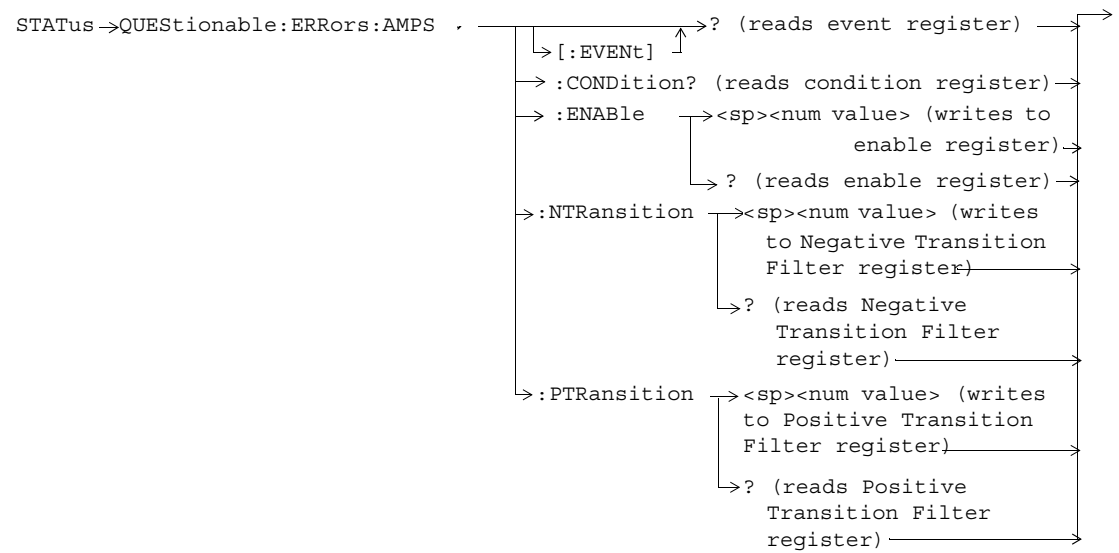

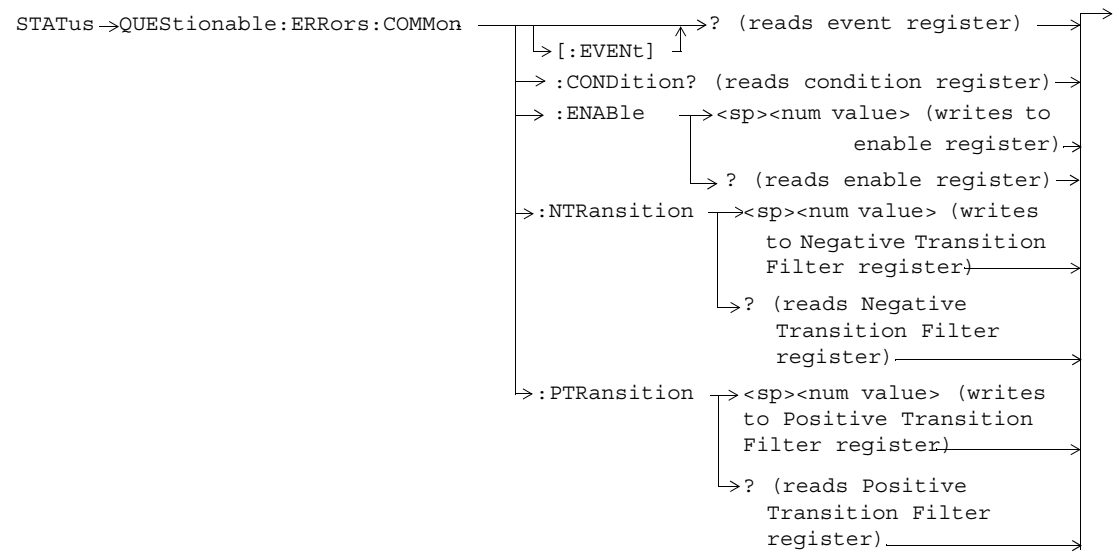

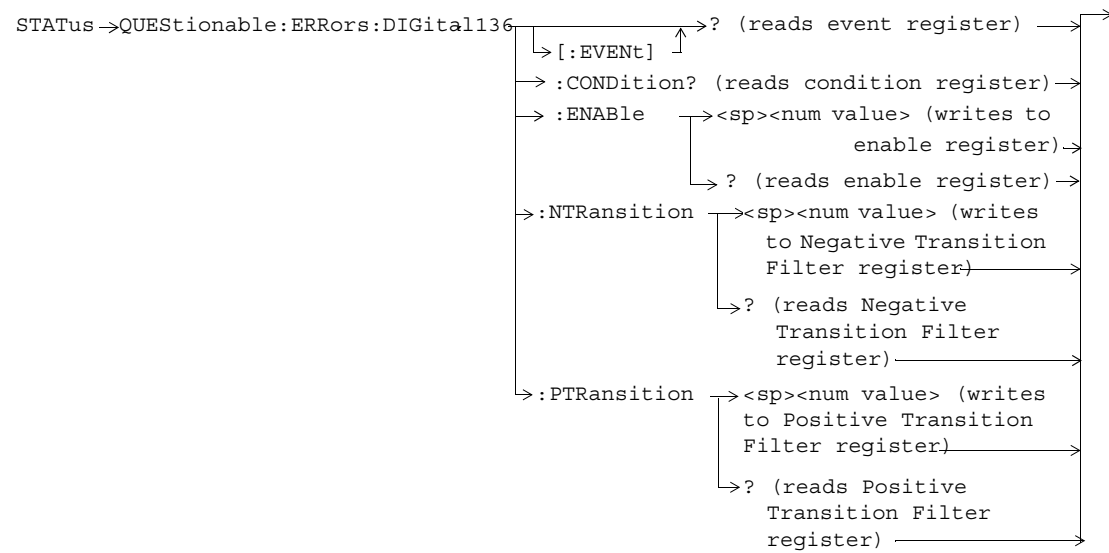

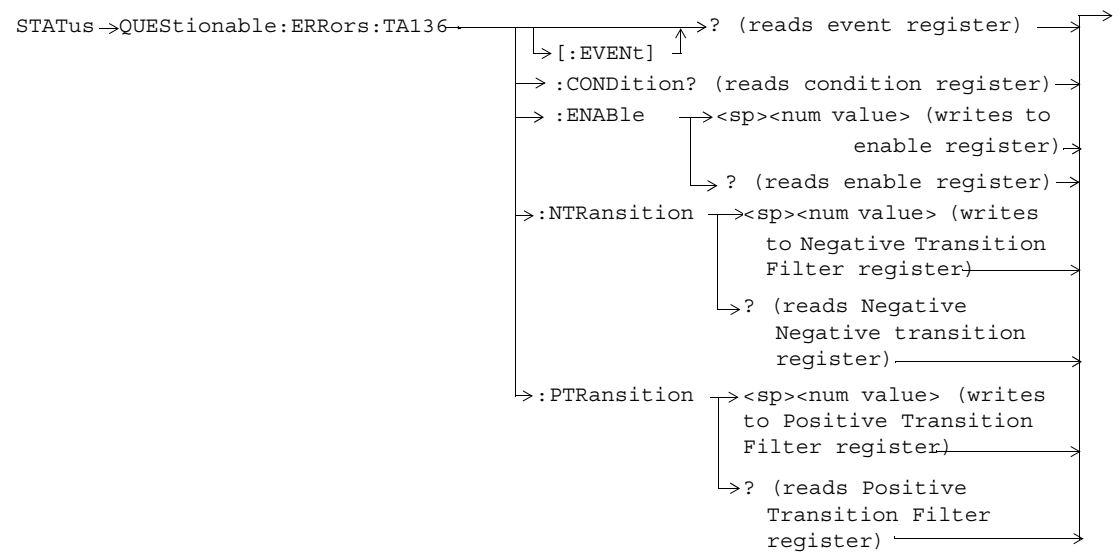

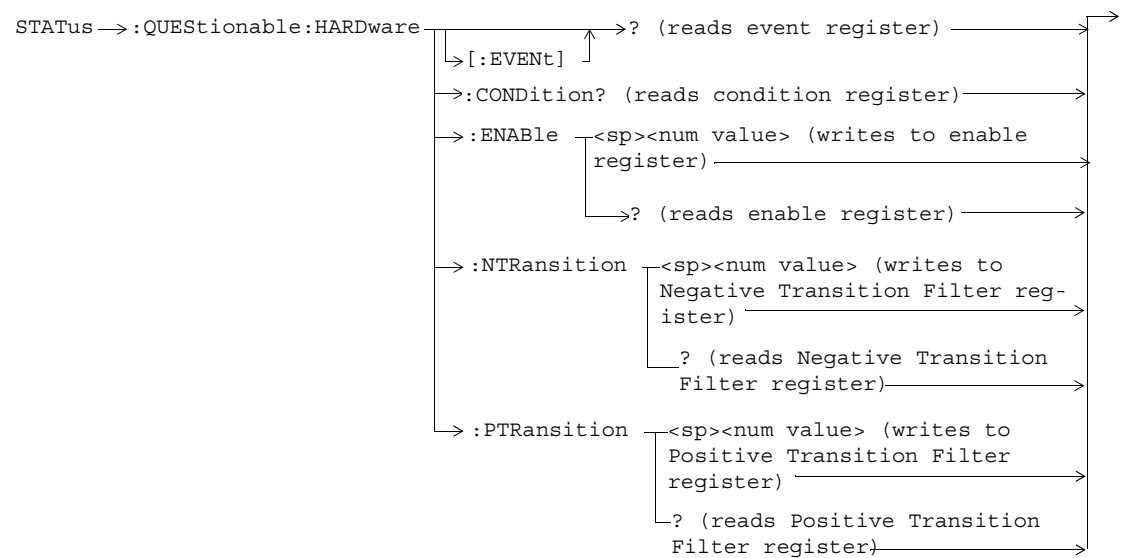



```

OUTPUT 714;"STATUS:QUESTIONABLE:EVENT?" !Queries and clears the Questionable Event
!Register
OUTPUT 714;"STATUS:QUESTIONABLE:CONDITION?" !Queries and clears the Questionable Condition
!Register
OUTPUT 714;"STATUS:QUESTIONABLE:ENABLE 1024" !Sets the Questionable Enable Register
!for bit 10
OUTPUT 714;"STATUS:QUESTIONABLE:NTRANSITION 2" !Sets the Questionable Negative
!Transition Filter Register for bit 1
OUTPUT 714;"STATUS:QUESTIONABLE:PTRANSITION 2" !Sets the Questionable Positive
!Transition Filter Register for bit 1

OUTPUT 714;"STATUS:QUESTIONABLE:CALL:EVENT?" !Queries and clears the Questionable
!Call Event Register
OUTPUT 714;"STATUS:QUESTIONABLE:CALL:CONDITION?" !Queries and clears the Questionable
!Call Condition Register
OUTPUT 714;"STATUS:QUESTIONABLE:CALL:ENABLE 1024" !Sets the Questionable
!Call Enable Register for bit 10
OUTPUT 714;"STATUS:QUESTIONABLE:CALL:NTRANSITION 2" !Sets the Questionable Call
!Negative Transition Filter Register
!for bit 1
OUTPUT 714;"STATUS:QUESTIONABLE:CALL:PTRANSITION 2" !Sets the Questionable Call
!Positive Transition Filter Register
!for bit 1

```

```

OUTPUT 714;"STATUS:QUESTIONABLE:ERRORS:EVENT?" !Queries and clears the Questionable
!Errors Event Register
OUTPUT 714;"STATUS:QUESTIONABLE:ERRORS:CONDITION?" !Queries and clears the Questionable
!Errors Condition Register
OUTPUT 714;"STATUS:QUESTIONABLE:ERRORS:ENABLE 1024" !Sets the Questionable
!Errors Enable
!Register for bit 10
OUTPUT 714;"STATUS:QUESTIONABLE:ERRORS:NTRANSITION 2" !Sets the Questionable Errors
!Negative Transition Filter Register
!for bit 1
OUTPUT 714;"STATUS:QUESTIONABLE:ERRORS:PTRANSITION 2" !Sets the Questionable Errors
!Positive Transition Filter Register
!for bit 1

OUTPUT 714;"STATUS:QUESTIONABLE:ERRORS:COMMON:EVENT?" !Queries and clears the Questionable
!Errors Common Event Register
OUTPUT 714;"STATUS:QUESTIONABLE:ERRORS:COMMON:CONDITION?" !Queries the and clears the
!Questionable Errors
!Common Condition Register
OUTPUT 714;"STATUS:QUESTIONABLE:ERRORS:COMMON:ENABLE 1024" !Sets the Questionable
!Errors Common Enable
!Register for bit 10
OUTPUT 714;"STATUS:QUESTIONABLE:ERRORS:COMMON:NTRANSITION 2" !Sets the Questionable Errors
!Common Negative Transition
!Register for bit 1

```

```

OUTPUT 714;"STATUS:QUESTIONABLE:ERRORS:COMMON:PTRANSITION 2" !Sets the Questionable Errors
!Common Positive Transition
!Register for bit 1

OUTPUT 714;"STATUS:QUESTIONABLE:ERRORS:AMPS:EVENT?" !Queries and clears the Questionable
!Errors AMPS Event Register

OUTPUT 714;"STATUS:QUESTIONABLE:ERRORS:AMPS:CONDITION?" !Queries and clears the Questionable
!Errors AMPS Condition Register

OUTPUT 714;"STATUS:QUESTIONABLE:ERRORS:AMPS:ENABLE 1024" !Sets the Questionable
!Errors AMPS Enable
!Register for bit 10

OUTPUT 714;"STATUS:QUESTIONABLE:ERRORS:AMPS:NTRANSITION 2" !Sets the Questionable Errors
!AMPS Negative Transition
!Filter Register for bit 1

OUTPUT 714;"STATUS:QUESTIONABLE:ERRORS:AMPS:PTRANSITION 2" !Sets the Questionable Errors
!AMPS Positive Transition
!Filter Register for bit 1

OUTPUT 714;"STATUS:QUESTIONABLE:ERRORS:DIGITAL136:EVENT?" !Queries and clears the
!Questionable Errors
!Digital136 Event Register

OUTPUT 714;"STATUS:QUESTIONABLE:ERRORS:DIGITAL136:CONDITION?" !Queries and clears the
!Questionable Errors
!Digital136 Condition Register

OUTPUT 714;"STATUS:QUESTIONABLE:ERRORS:DIGITAL136:ENABLE 1024" !Sets the Questionable
!Errors Digital136 Enable

```

```

!Register for bit 10
OUTPUT 714;"STATUS:QUESTIONABLE:ERRORS:DIGITAL136:NTRANSITION 2" !Sets the Questionable
!Errors Digital136 Negative
!Transition Filter
!Register for bit 1
OUTPUT 714;"STATUS:QUESTIONABLE:ERRORS:DIGITAL136:PTRANSITION 2" !Sets the Questionable
!Errors Digital136 Positive
!Transition Filter
!Register for bit 1

OUTPUT 714;"STATUS:QUESTIONABLE:ERRORS:TA136:EVENT?" !Queries and clears the
!Questionable Errors
!TA136 Event Register
OUTPUT 714;"STATUS:QUESTIONABLE:ERRORS:TA136:CONDITION?" !Queries and clears the
!Questionable Errors
!TA136 Condition Register
OUTPUT 714;"STATUS:QUESTIONABLE:ERRORS:TA136:ENABLE 1024" !Sets the Questionable
!Errors TA136 Enable
!Register for bit 10
OUTPUT 714;"STATUS:QUESTIONABLE:ERRORS:TA136:NTRANSITION 2" !Sets the Questionable
!Errors TA136 Negative
!Transition Filter
!Register for bit 1
OUTPUT 714;"STATUS:QUESTIONABLE:ERRORS:TA136:PTRANSITION 2" !Sets the Questionable
!Errors TA136 Positive

```

```

!Transition Filter
!Register for bit 1
OUTPUT 714;"STATUS:QUESTIONABLE:HARDWARE:EVENT?" !Queries and clears the Questionable
!Hardware Event Register
OUTPUT 714;"STATUS:QUESTIONABLE:HARDWARE:CONDITION?" !Queries and clears the Questionable
!Hardware Condition Register
OUTPUT 714;"STATUS:QUESTIONABLE:HARDWARE:ENABLE 1024" !Sets the Questionable
!Hardware Enable
!Register for bit 10
OUTPUT 714;"STATUS:QUESTIONABLE:HARDWARE:NTRANSITION 2" !Sets the Questionable
!Hardware Negative Transition Filter
!Register for bit 1
OUTPUT 714;"STATUS:QUESTIONABLE:HARDWARE:PTRANSITION 2" !Sets the Questionable
!Hardware Positive Transition Filter
!Register for bit 1

```

## Status Byte Register

**\*STB?**

\*STB? \_\_\_\_\_ ↘

---

**NOTE**      The Status Byte Register can also be read with a serial poll. For example, the command “Status\_byte = SPOLL(714)” would perform a serial poll of the Status Byte Register, returning and releasing RQS (bit 6).

---

### Status Byte Register Bit Assignments

Bit Number	Binary Weighting	Label	Description
7	128	STATUS: OPERATION	Summarizes the STATUS: OPERATION Status Register, which fans out to the NMRReady and CALL Status Registers.
6	64	RQS (SRQ TRUE?)/Master Summary Status	RQS is read by a serial poll (SPOLL) Master Summary Status is read by a *STB? query - defined by IEEE 488.2
5	32	Standard Event Status Register	Summarizes the Standard Event Status Register
4	16	Message Available	SCPI - Defined
3	8	STATUS: QUESTIONABLE Status Register	Summary Message comes from the STATUS: QUESTIONABLE Status Register, which fans out to the CALL and HARDWARE Status Registers
2	4	Error/ Event Queue	SCPI - Defined

<b>Bit Number</b>	<b>Binary Weighting</b>	<b>Label</b>	<b>Description</b>
1	2	Reserved	
0	1	Reserved	

**Status Byte Register Bit Assignments**



## Standard Event Status Register

### \*ESR?

\*ESR? → Reads and clears the Std Event Status Register. →

### \*ESE?

\*ESE? → Reads the Std Event Status Register Enable Register →

### \*ESE

\*ESE → Writes to the Std Event Status Register Enable Register →

“Diagram Conventions” on page 7

**Standard Event Status Register Bit Assignment**

<b>Bit Number</b>	<b>Binary Weighting</b>	<b>Condition</b>	<b>Description</b>
15	32768	Reserved by IEEE.	This bit will always be 0.
14	16384	Reserved by IEEE.	This bit will always be 0.
13	8192	Reserved by IEEE.	This bit will always be 0.
12	4096	Reserved by IEEE.	This bit will always be 0.
11	2048	Reserved by IEEE.	This bit will always be 0.
10	1024	Reserved by IEEE.	This bit will always be 0.
9	512	Reserved by IEEE.	This bit will always be 0.
8	256	Reserved by IEEE.	This bit will always be 0.
7	128	Power On	This bit is set to 1 if the power supply has been turned off and on since the last time this register was read or otherwise cleared. Defined in "IEEE Std. 488.2-1992", 11.5.1.1.2
6	64	Reserved for future use.	This bit will always be 0.

Bit Number	Binary Weighting	Condition	Description
5	32	Command Error	<p>This bit is set to 1 if the test set detects an error while trying to process a command. The following events cause a command error:</p> <ul style="list-style-type: none"> <li>• An IEEE 488.2 syntax error. The test set received a message that did not follow the syntax defined by the standard.</li> <li>• A semantic error. For example the test set received an incorrectly spelled command.</li> <li>• The test set received a group execution trigger (GET) inside a program message</li> </ul>

Bit Number	Binary Weighting	Condition	Description
4	16	Execution Error	<p>This bit is set to 1 if the test set detects an error while trying to execute a command. The following events cause a execution error:</p> <ul style="list-style-type: none"> <li>• A &lt;PROGRAM DATA&gt; element received in a command is outside the legal range for the test set, or it is inconsistent with the operation of the test set.</li> <li>• The test set could not execute a valid command due to some test set hardware/firmware condition.</li> </ul>
3	8	Device Dependent Error	<p>This bit is set to 1 if a test set operation does not execute properly due to an internal condition (such as, overrange). This bit indicates that the error was not a command, query, or execution error.</p>

Bit Number	Binary Weighting	Condition	Description
2	4	Query Error	<p>This bit is set to 1 if an error has occurred while trying to read the test set's output queue. The following events cause a query error:</p> <ul style="list-style-type: none"> <li>• An attempt is made to read data from the output queue when no data is present or is pending.</li> <li>• Data in the output queue has been lost. An example of this would be an output queue overflow.</li> </ul>
1	2	Reserved for future use.	This bit will always be 0.
0	1	Operation Complete	This bit is set to 1 when the test set has completed all pending operations and is ready to accept new commands. This bit is only generated in response to the *OPC IEEE 488.2 common command.

## SYSTEM:APPLICATION

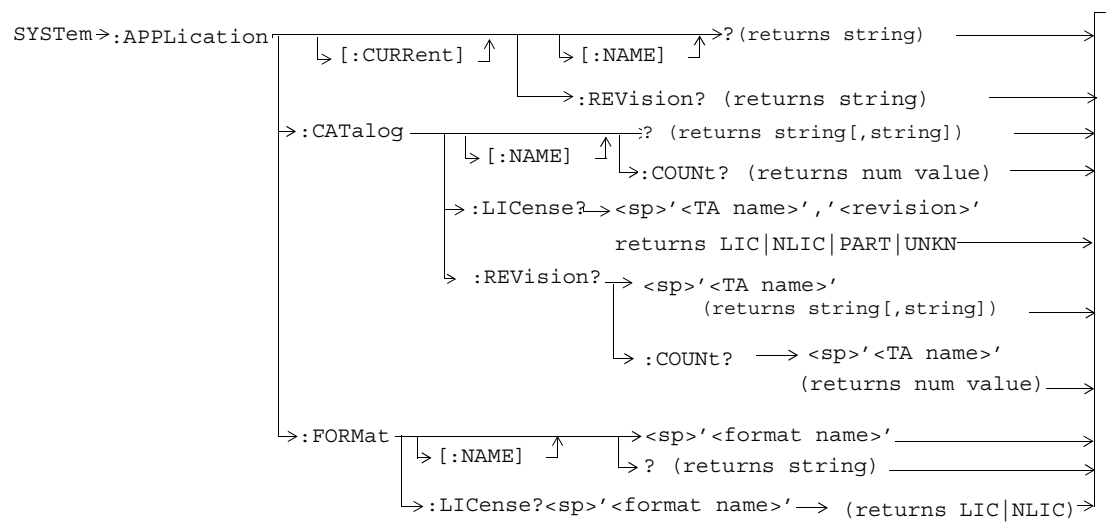

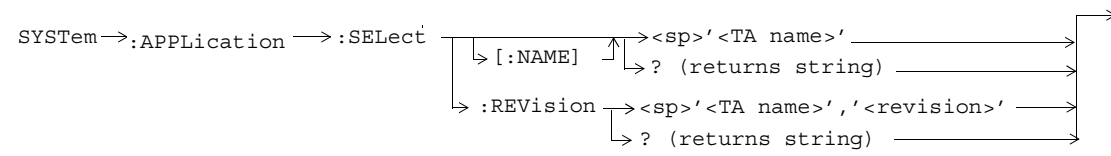

### **SYSTem:BEEPer**

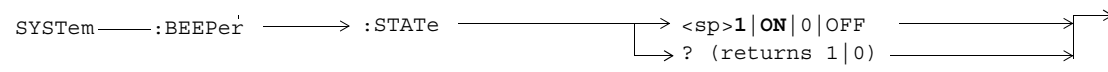



## SYSTem:COMMunicate

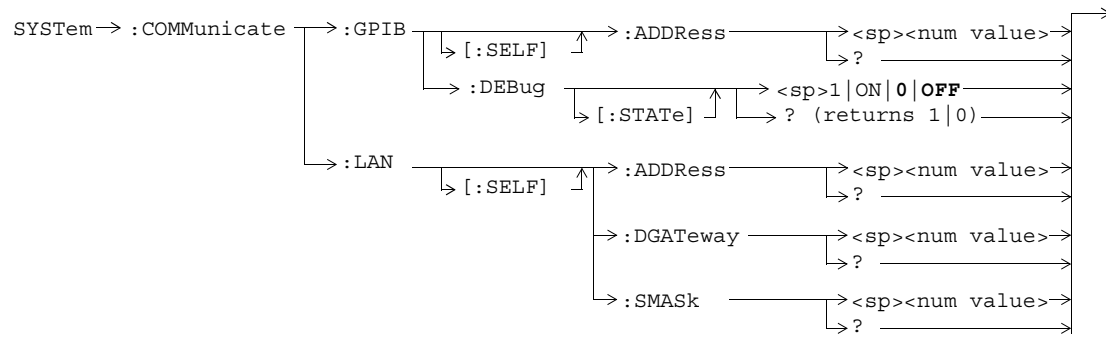

## **SYSTem:CONFigure:INFormation:HARDware:VERBose?**

SYSTem——:CONFigure ——> :INFormation ——>:HARDware ——>:VERBose? ——>

## SYSTem:CORRection

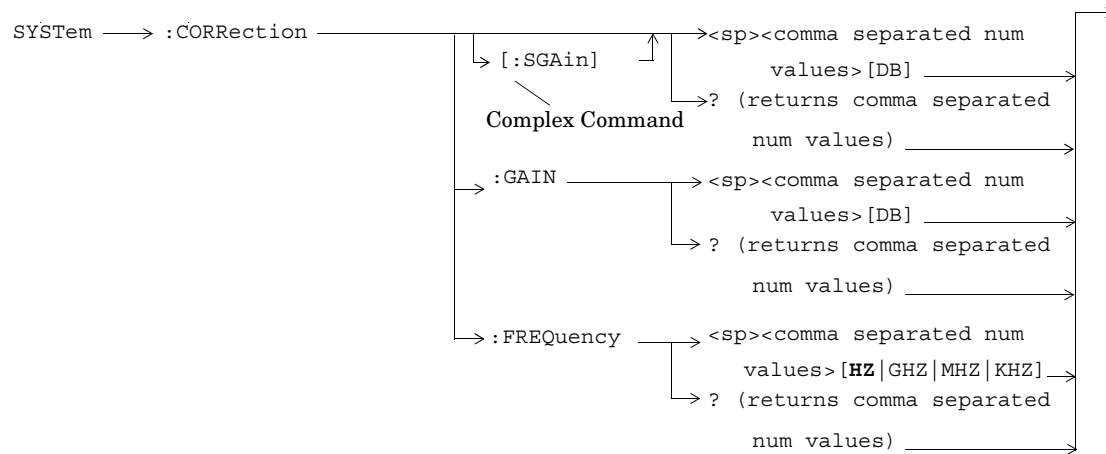

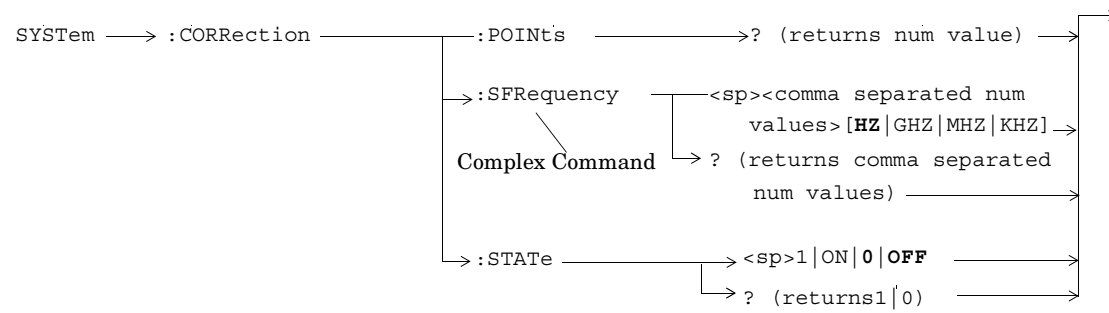

### **SYSTem:CURRent:TA**

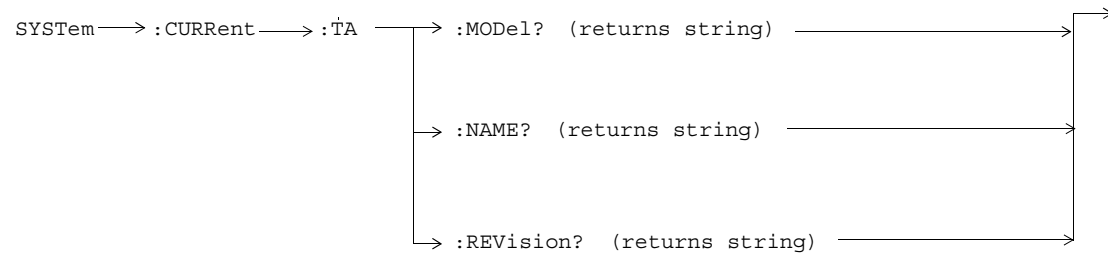

## **SYSTem:ERRor?**

SYSTem → :ERRor? →

## **SYSTem:MEASurement:RESet**

SYSTem → :MEASurement → :RESet →

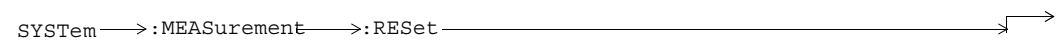

### **SYSTem:PRESet**

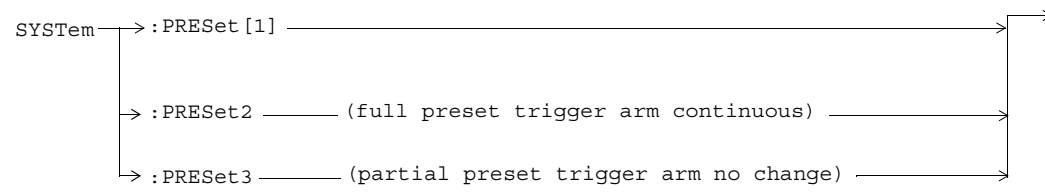



### **SYSTem:ROSCillator**

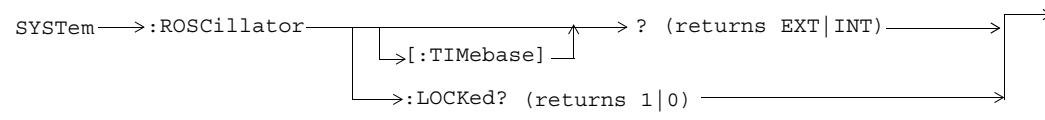

### **SYSTem:SYNChronized**

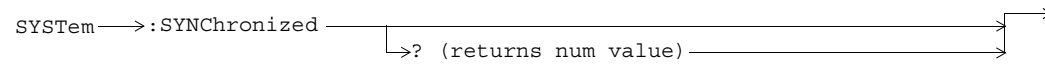

## **IEEE 488.2 Common Commands**

### **Description**

#### **\*CLS**

The \*CLS, clear status command, is defined in “IEEE Std 488.2-1992”, 10.3. This command will also clear and close the error message screen on the test set’s display.

#### **\*ESE**

The \*ESE, standard event status enable command, is defined in “IEEE Std 488.2-1992”, 10.10.

#### **\*ESE?**

The \*ESE?, standard event status enable query, is defined in “IEEE Std 488.2-1992”, 10.11.

#### **\*ESR?**

The \*ESR?, standard event status register query, is defined in “IEEE Std 488.2-1992 “,10.12.

#### **\*IDN?**

The \*IDN?, identification query is defined in “IEEE Std 488.2-1992”, 10.14. \*IDN? is used to retrieve information about the test set in ASCII format.

**\*IDN?**, returns ASCII codes 32 through 126 excluding comma and semicolon in four comma separated fields. Field 1 returns the manufacturer, field 2 returns the instrument model number, field 3 returns the serial number, field 4 returns 0.

**\*OPC**

The **\*OPC**, operation complete command, is defined in “IEEE 488.2-1992”, 10.18. **\*OPC** causes the test set to continuously sense the No Operation Pending flag. When the No Operation Pending flag becomes TRUE, the OPC event bit in the standard event status register (ESR) is set to indicate that the state of all pending operations is completed. The **\*OPC** common command is not recommended for use as an overlapped command.

**\*OPC?**

The **\*OPC?**, operation complete query, is defined in “IEEE Std 488.2-1992”, 10.19. The **\*OPC?** query allows synchronization between the controller and the test set using either the message available (MAV) bit in the status byte, or a read of the output **OPC?**. The **\*OPC?** query does not effect the OPC event bit in the Standard Event Status Register (ESR). The **\*OPC?** common command is not recommended for use as an overlapped command.

**\*OPT?**

The **\*OPT?**, option identification query, is defined in “IEEE Std 488.2-1992”, 10.20. Each option will have a unique name, that name will be returned with the query.

**\*RST**

The **\*RST**, full preset command, is defined in “IEEE Std 488.2-1992”, 10.32. A full preset is also accomplished

using the `SYSTEM:PRESet2` command. A full preset restores the majority of settings to their default values and sets measurement trigger arm to single.

**\*SRE**

The `*SRE`, service request enable command, is defined in “IEEE Std 488.2-1992”, 10.34. The parameter range for this command is 0 through 255.

**\*SRE?**

The `*SRE?`, service request enable query, is defined in “IEEE Std 488.2-1992”, 10.35. Values returned by this query range from 0 through 255.

**\*STB?**

The `*STB?`, read status byte query, is defined in “IEEE Std 488.2-1992”, 10.36. Values returned by this query range from 0 through 255.

**\*WAI**

The `*WAI`, wait-to-continue command, is defined in “IEEE Std 488.2-1992”, 10.39. The `*WAI` command prevents the test set from executing any further commands or queries until all pending operation flags are false. The `*WAI` common command is not recommended for use as an overlapped command.

---

## Syntax Equivalents

### Numerics

100 Hz BW BPF Center Frequency, 93  
  audio analyzer, 82  
1st Alternate, 49  
2nd Alternate, 49

### A

ACC (control channel type), 17  
ACC Channel, 15  
ACP  
  *See also* Adjacent Channel Power  
Active Cell, 32  
Active Cell Status, 18  
Adjacent Channel Power  
  1st Alternate (Lower, Upper), 49  
  2nd Alternate (Lower, Upper), 49  
  Adjacent (Lower, Upper), 49  
  average, 73  
Adjacent Channel Power Setup  
  Measurement Timeout, 80  
  Multi-Measurement Count, 79  
  Trigger Arm, 79  
  Trigger Delay, 80  
  Trigger Source, 80  
Amplitude, 13  
Amplitude Offset RF In/Out Port, 139  
Analog MS TX Level (AVC setup info), 42  
Analog MS TX Level (current AVC info), 45  
Analog Transmit Power  
  average, 73

  integrity, 54  
  intermediate count, 54  
  Minimum, Maximum, Average, Std Dev,  
    54  
Analog Transmit Power Setup  
  Measurement Timeout, 86  
  Multi-Measurement Count, 85  
  Trigger Arm, 85  
ATXP  
  *See also* Analog Transmit Power  
Audio Analyzer  
  Audio Frequency, 51  
  Audio Level, 52  
  Distortion, 51  
  integrity, 51  
  intermediate count, 51  
  SINAD, 52  
Audio Analyzer Setup  
  100 Hz BW BPF Center Frequency, 82  
  De-Emphasis State, 81  
  Detector Type, 82  
  Expander Reference Level, 82  
  Filter Type, 82  
  Measurement Timeout, 82  
  Multi-Measurement Count, 81  
  SINAD/Distortion Fundamental  
    Frequency, 82  
  SINAD/Distortion State, 82  
  Trigger Arm, 81  
Audio Frequency, 51

Audio Generator, 13  
Audio Level, 52  
  average, 73  
AVC (traffic channel type), 46  
AVC Channel, 41  
AVC Channel (current AVC info), 45  
AVC Setup Info  
  Analog MS TX Level, 42  
  AVC Channel, 41  
  SAT Color Code, 41  
AVC Test, 32

### B

Band Pass Filter Frequency  
  FM, 93  
Beeper State, 136  
Bit Error Count, 64, 74  
Bit Error Ratio, 64, 74

### C

Cal. first IQ mod, 14  
Cal. second IQ mod, 14  
Cell Power, 37  
Cell Power (CW parameters), 37  
Cell Power State (CW parameters), 37  
Cellular (DCCH band), 20  
Cellular (DTC band), 41  
Change MS TX Level, 27  
Clear Message Log, 47

---

## Syntax Equivalents

- Control Ch Type
  - ACC, 17
  - DCCH, 17
- Coupling, 13
- Current AVC Info
  - Analog MS TX Level, 45
  - AVC Channel, 45
  - SAT Color Code, 45
- Current DTC Info
  - Digital MS TX Level, 45
  - DTC Band, 45
  - DTC Channel, 45
  - DTC Vocoder Type, 45
- Current Traffic Channel Type, 45
- CW, 32
- CW Parameters
  - Cell Power, 37
  - Cell Power State, 37
  - RF Generator Frequency, 39
- D**
- DCCH (control channel type), 17
- DCCH Band
  - Cellular, 20
  - PCS, 20
- DCCH Channel, 20
- debug feature, 11
- Debug State, 137
- De-Emphasis State
  - audio analyzer, 81
  - FM, 91
- Default Gateway, 137
- Detector Type
  - Peak -, 92
  - Peak (audio analyzer), 82
  - Peak +, 92
  - RMS (audio analyzer), 82
  - RMS (FM), 92
- Digital MS Protocol Version (mobile station information), 31
- Digital MS TX Level (current DTC info), 45
- Digital MS TX Level (DTC setup info), 42
- Digital Transmit Power
  - average, 73
  - intermediate count, 57
  - Minimum, Maximum, Average, Std Dev, 57
- Digital Transmit Power Setup
  - Measurement Timeout, 90
  - Multi-Measurement Count, 89
  - Trigger Arm, 89
  - Trigger Delay, 90
  - Trigger Source, 90
- DigitalTransmit Power
  - integrity, 57
- Disable MAHO Reporting, 28
- Display Brightness
  - High, 47
  - Medium, 47
- Display Mode
  - Fast, 47
  - Track, 47
- Display mode, 47
- Distortion
  - audio, 51
  - audio (average), 73
  - FM, 60
  - FM (average), 73
- Distortion (%)
  - Minimum, Maximum, Average, 60
- Distortion Fundamental Frequency, 92
- Distortion State, 92
- DTC (traffic channel type), 46
- DTC Band
  - Cellular, 41
  - PCS, 41
- DTC Band (current DTC info), 45
- DTC Burst Size
  - Normal, 21
  - Shortened, 21
- DTC Channel, 41
- DTC Channel (current DTC info), 45
- DTC Induced Err, 23
- DTC Setup Info
  - Digital MS TX Level, 42
- DTC Test, 32
- DTC Vocoder Type
  - ACELP(CC1), 41
  - VSELP, 41
- DTC Vocoder Type (current DTC info), 45

---

## Syntax Equivalents

- DTXP  
*See also* Digital Transmit Power
- E**
- Enable MAHO Reporting, 28
  - End Call, 22
  - ESN (Decimal) (mobile station information), 27
  - ESN (Hex) (mobile station information), 27
  - EVM  
*See also* RMS EVM
  - EVM1
    - maximum, 74
  - EVM10
    - maximum, 74
  - EVM10 Measurement, 99, 103
  - Execute Handoff, 25
  - Expander Reference Level
    - audio analyzer, 82
  - Expander State, 92
  - Expected CW Power (receiver control), 75
  - Expected Power Control (receiver control), 75
  - Ext FM State, 24
- F**
- Filter Type
    - 100 Hz BW BPF (audio analyzer), 82
    - 100 Hz BW BPF (FM), 93
    - 300 Hz to 15 kHz (audio analyzer), 82
    - 300 to 15 k (FM), 93
    - 50 Hz to 15 kHz (audio analyzer), 82
    - 50 to 15 k (FM), 93
    - C-Message (audio analyzer), 82
    - C-Message (FM), 93
    - None (audio analyzer), 82
    - None (FM), 93
  - FM Dev (kHz) RMS
    - Minimum, Maximum, Average, 59
  - FM Deviation, 59
    - average, 73
  - Freq Error (Hz)
    - Minimum, Maximum, Average, 67
    - Minimum, Maximum, Average, 62
  - Frequency, 13
    - frequency stability, 62
    - frequency stability (average), 74
  - Frequency (kHz)
    - Minimum, Maximum, Average, 62
  - Frequency Error, 62
    - modulation accuracy, 67
  - Frequency Modulation
    - Distortion, 60
    - FM Deviation, 59
    - integrity, 60
    - intermediate count, 60
    - Modulation Frequency, 60
  - Frequency Modulation Setup
    - 100 Hz BW BPF Center Frequency, 93
  - De-Emphasis State, 91
  - Detector Type, 92
  - Distortion Fundamental Frequency, 92
  - Distortion State, 92
  - Expander State, 92
  - Filter Type, 93
  - Measurement Timeout, 93
  - Multi-Measurement Count, 91
  - Trigger Arm, 91
- I**
- Frequency Stability
    - Frequency, 62
    - Frequency Error, 62
    - integrity, 62
    - intermediate count, 62
    - Worst Frequency Error, 62
  - Frequency Stability Setup
    - Measurement Timeout, 96
    - Multi-Measurement Count, 95
    - Trigger Arm, 95
- G**
- GPIB Address, 137
- I**
- Instrument Information
    - Last Calibration, 14
    - Test Application, 141
  - Instrument Setup
    - Beeper State, 136



---

## Syntax Equivalents

- Default Gateway, 137
- Display Brightness, 47
- Display Mode, 47
- GPIO Address, 137
- LAN IP Address, 137
- Maskable Message Display State, 47
- Subnet Mask, 137
- Int FM Dev, 24
- Int FM Freq, 24
- integrity
  - analog transmit power, 54
  - audio measurements, 51
  - digital transmit power, 57
  - FM, 60
  - frequency stability, 62
- intermediate count
  - analog transmit power, 54
  - audio measurements, 51
  - digital transmit power, 57
  - FM, 60
  - frequency stability, 62
- IQ Tuning
  - FETCh, 63
- L**
  - LAN IP Address, 137
  - Last Calibration, 14
  - Loopback BER
    - Bit Error Count, 64
    - Bit Error Ratio, 64
    - bits tested, 74
  - Loopback BER Setup
    - Measurement Timeout, 101
    - Number of bits to test, 101
    - Trigger Arm, 101
- M**
  - MACC
    - See also* Modulation Accuracy
  - Magnitude Error
    - maximum, 74
    - See Also* RMS Magnitude Error
  - MAHO BER, 28
  - MAHO Info, 28
  - MAHO Reported Information, 28
  - MAHO RSSI, 28
  - Manual Analog Power Cellular Band (receiver control), 76
  - Manual Digital Power Cellular Band (receiver control), 76
  - Manual Digital Power PCS Band (receiver control), 76
  - Maskable Message Display State, 47
  - MCC, 26
  - Measurement Frequency
    - Auto (receiver control), 75
    - manual (receiver control), 77
  - Measurement Timeout
    - adjacent channel power, 80
    - analog transmit power, 86
    - audio analyzer, 82
    - digital transmit power, 90
    - FM, 93
    - frequency stability, 96
    - Loopback BER, 101
    - modulation accuracy, 99, 103
  - Message Log, 142
  - Min 1 (Hex) (mobile station information), 31
  - Min 2 (Hex) (mobile station information), 31
  - Mobile Station Information
    - Digital MS Protocol Version, 31
    - ESN (Decimal), 27
    - ESN (Hex), 27
    - Min 1 (Hex), 31
    - Min 2 (Hex), 31
    - MS Called Party Number, 31
    - Phone Number, 31
    - Rate Capability, 31
    - SCM, 31
  - Modulation Accuracy
    - Frequency Error, 67
    - Origin Offset, 69
    - RMS EVM1, 66
    - RMS EVM10, 66
    - RMS Magnitude Error, 67
    - RMS Phase Error, 69
  - Modulation Accuracy Setup
    - EVM10 Measurement, 99, 103

---

## Syntax Equivalents

Measurement Timeout, 99, 103  
Multi-Measurement Count, 98, 103  
Trigger Arm, 98, 103  
Trigger Delay, 99, 103  
Trigger Source, 99, 103  
Modulation Frequency, 60  
MS Called Party Number (mobile station information), 31  
MS TX Level, 42  
Multi-Measurement Count  
adjacent channel power, 79  
analog transmit power, 85  
audio analyzer, 81  
digital transmit power, 89  
FM, 91  
frequency stability, 95  
modulation accuracy, 98, 103

### N

Normal (DTC burst size), 21  
Number of bits to test  
Loopback BER, 101

### O

Operating Mode  
Active Cell, 32  
AVC Test, 32  
CW, 32  
DTC Test, 32

Origin Offset  
maximum, 74  
modulation accuracy, 69  
Origin Offset (dBc)  
Minimum, Maximum, Average, 69  
Originate Call, 33

### P

Paging Number, 34, 35, 38  
PCS (DCCH band), 20  
PCS (DTC band), 41  
Phase Error  
maximum, 74  
*See Also* RMS Phase Error  
Phone Number (mobile station information), 31  
Port Configuration  
Amplitude Offset (RF In/Out port), 139  
programming, debug feature, 11  
Pulse, 13

### R

Rate Capability (mobile station information), 31  
Receiver Control  
Expected CW Power, 75  
Expected Power Control, 75  
Manual Analog Power Cellular Band, 76  
Manual Digital Power Cellular Band, 76

Manual Digital Power PCS Band, 76  
Measurement Frequency  
Auto, 75  
manual, 77  
Uplink Frequency  
Auto, 75  
manual, 77  
Rev, License, 135  
RF Gen Freq, 39  
RF Gen Freq Ctrl, 19  
RF Generator Frequency (CW parameters), 39  
RMS EVM1  
modulation accuracy, 66  
RMS EVM1 (%)  
Minimum, Maximum, Average, 66  
RMS EVM10  
modulation accuracy, 66  
RMS EVM10 (%)  
Minimum, Maximum, Average, 66  
RMS Mag Error (%)  
Minimum, Maximum, Average, 67  
RMS Magnitude Error  
modulation accuracy, 67  
RMS Phase Error (degrees)  
Minimum, Maximum, Average, 69  
RMSPhase Error  
modulation accuracy, 69

---

## Syntax Equivalents

### S

SAT Color Code, 41  
SAT Color Code (current AVC info), 45  
SAT State, 16  
SCM (mobile station information), 31  
Shortened (DTC burst size), 21  
SINAD, 52  
    average, 73  
SINAD/Distortion Fundamental  
    Frequency, 82  
    audio analyzer, 82  
SINAD/Distortion State, 82  
    audio analyzer, 82  
SOC, 44  
Subnet Mask, 137  
System ID, 43

### T

Test Application  
    Test Application, Revision, License, 135  
Test Application (instrument information),  
    141  
Test Application Setup, 135  
Traffic Ch Type  
    AVC, 46  
    DTC, 46  
Trigger Arm  
    adjacent channel power, 79  
    analog transmit power, 85  
    audio analyzer, 81

    digital transmit power, 89  
    FM, 91  
    frequency stability, 95  
    Loopback BER, 101  
    modulation accuracy, 98, 103  
Trigger Delay  
    adjacent channel power, 80  
    digital transmit power, 90  
    IQ Tuning, 99  
    MACC, 103  
Trigger Source  
    adjacent channel power, 80  
    digital transmit power, 90  
    IQ Tuning, 99  
    MACC, 103

### U

Uplink Frequency  
    Auto (receiver control), 75  
    manual (receiver control), 77

### V

Vocoder Type  
    ACELP(CC1), 41  
    VSELP, 41

### W

Worst Frequency Error, 62, 74